

Operator's Manual

Trench Roller

RT82-SC3

RTx-SC3

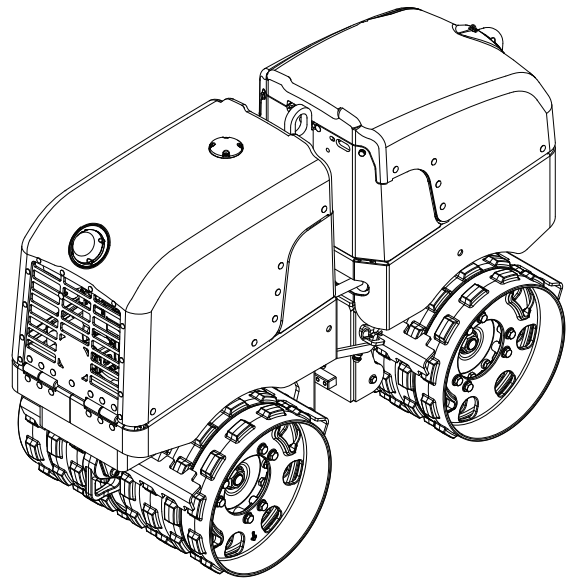

EN

5200023365	03	0415
------------	----	------



Copyright notice

© Copyright 2015 by Wacker Neuson Production Americas LLC

All rights, including copying and distribution rights, are reserved.

This publication may be photocopied by the original purchaser of the machine. Any other type of reproduction is prohibited without express written permission from Wacker Neuson Production Americas LLC.

Any type of reproduction or distribution not authorized by Wacker Neuson Production Americas LLC represents an infringement of valid copyrights. Violators will be prosecuted.

Trademarks

All trademarks referenced in this manual are the property of their respective owners.

Manufacturer

Wacker Neuson Production Americas LLC

N92W15000 Anthony Avenue

Menomonee Falls, WI 53051 U.S.A.

Tel: (262) 255-0500 · Fax: (262) 255-0550 · Tel: (800) 770-0957

www.wackerneuson.com

Original instructions

This Operator's Manual presents the original instructions. The original language of this Operator's Manual is American English.

Foreword

SAVE THESE INSTRUCTIONS—This manual contains important instructions for the machine models below. These instructions have been written expressly by Wacker Neuson Production Americas LLC and must be followed during installation, operation, and maintenance of the machines.

Machine	Item Number
RT82-SC3	5200019232, 5200019233, 5200019234, 5200019235, 5200019236, 5200019237, 5200019238, 5200019239, 5200022541, 5200019255, 5200019256
RTx-SC3	5200019250, 5200019251, 5200019252, 5200019253, 5200019254, 5200019257, 5200019258, 5200019259, 5100013934, 5100013935

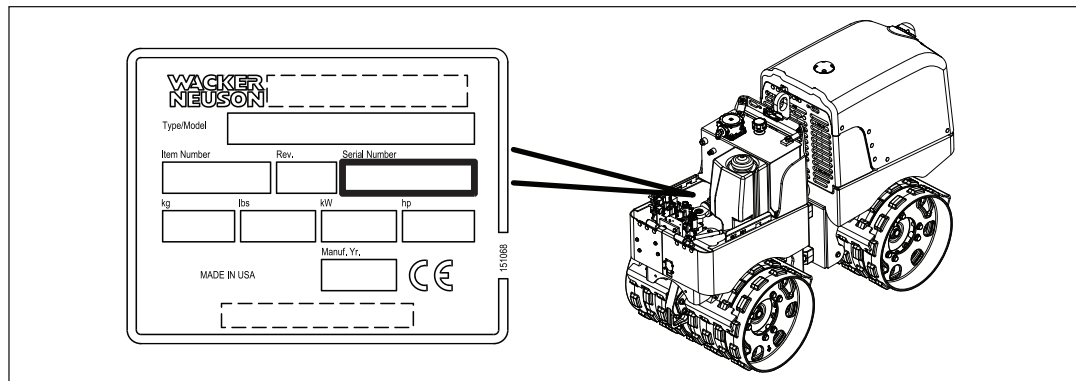

wc_gr012199

Machine identification

A nameplate listing the model number, item number, revision number, and serial number is attached to this machine. The location of the nameplate is shown above.

Serial number (S/N)

For future reference, record the serial number in the space provided below. You will need the serial number when requesting parts or service for this machine.

Serial Number:

Machine documentation

- From this point forward in this documentation, Wacker Neuson Production Americas LLC will be referred to as Wacker Neuson.
 - Keep a copy of the Operator's Manual with the machine at all times.
 - Use the separate Parts Book supplied with the machine to order replacement parts.
 - If you are missing any of these documents, please contact Wacker Neuson to order a replacement or visit www.wackerneuson.com.
 - When ordering parts or requesting service information, be prepared to provide the machine model number, item number, revision number, and serial number.
-

Expectations for information in this manual

- This manual provides information and procedures to safely operate and maintain the above Wacker Neuson model(s). For your own safety and to reduce the risk of injury, carefully read, understand, and observe all instructions described in this manual.
 - Wacker Neuson expressly reserves the right to make technical modifications, even without notice, which improve the performance or safety standards of its machines.
 - The information contained in this manual is based on machines manufactured up until the time of publication. Wacker Neuson reserves the right to change any portion of this information without notice.
 - The illustrations, parts, and procedures in this manual refer to Wacker Neuson factory-installed components. Your machine may vary depending on the requirements of your specific region.
-

CALIFORNIA Proposition 65 Warning

Engine exhaust, some of its constituents, and certain vehicle components contain or emit chemicals known to the State of California to cause cancer and birth defects or other reproductive harm.

Laws pertaining to spark arresters

NOTICE: State Health Safety Codes and Public Resources Codes specify that in certain locations spark arresters be used on internal combustion engines that use hydrocarbon fuels. A spark arrester is a device designed to prevent accidental discharge of sparks or flames from the engine exhaust. Spark arresters are qualified and rated by the United States Forest Service for this purpose. In order to comply with local laws regarding spark arresters, consult the engine distributor or the local Health and Safety Administrator.

Manufacturer's approval

This manual contains references to *approved* parts, attachments, and modifications. The following definitions apply:

- **Approved parts or attachments** are those either manufactured or provided by Wacker Neuson.
- **Approved modifications** are those performed by an authorized Wacker Neuson service center according to written instructions published by Wacker Neuson.
- **Unapproved parts, attachments, and modifications** are those that do not meet the approved criteria.

Unapproved parts, attachments, or modifications may have the following consequences:

- Serious injury hazards to the operator and persons in the work area
- Permanent damage to the machine which will not be covered under warranty

Contact your Wacker Neuson dealer immediately if you have questions about approved or unapproved parts, attachments, or modifications.



EC Declaration of conformity

Manufacturer

Wacker Neuson Production Americas LLC, N92W15000 Anthony Avenue,
Menomonee Falls, Wisconsin 53051 USA

Product

Product	RT82-SC3, RTx-SC3
Product category	Trench Roller
Product function	To compact soil
Item number	5200019235, 5200019236, 5200019237 5200019238, 5200019239, 5200019252 5200019253, 5200019254, 5200022541
Net installed power	15.5 kW
Measured sound power level	106 dB(A)
Guaranteed sound power level	109 dB(A)

Conformity Assessment Procedure

According to 2000/14/EC ANNEX VIII

Notified Body

Lloyds Register Verification Limited (Notified Body No 0038)
71 Fenchurch Street, London EC3M 4BS, United Kingdom

Directives and Standards

We hereby declare that this product meets and complies with the relevant regulations and requirements of the following directives and standards:

2006/42/EC, 2000/14/EC, 2005/88/EC, 2004/108/EC, EN 500-1, EN 500-4

Authorized Person for Technical Documents

Leo Goeschka, Wacker Neuson Produktion GmbH & Co. KG, Preußenstraße 41,
80809 München

Menomonee Falls, WI, USA, 20.02.2015

Keith Herr
Managing Director
For Wacker Neuson

Dan Domanski
Technical Director
For Wacker Neuson

Paul Sina
Manager, Product Engineering
For Wacker Neuson



EC Declaration of conformity

Manufacturer

Wacker Neuson Production Americas LLC, N92W15000 Anthony Avenue,
Menomonee Falls, Wisconsin 53051 USA

Product

Product	RT82-SC3, RTx-SC3
Product category	Trench Roller
Product function	To compact soil
Item number	5200019256, 5200019259
Net installed power	15.5 kW
Measured sound power level	105 dB(A)
Guaranteed sound power level	109 dB(A)

Conformity Assessment Procedure

According to 2000/14/EC ANNEX VIII

Notified Body

Lloyds Register Verification Limited (Notified Body No 0038)
71 Fenchurch Street, London EC3M 4BS, United Kingdom

Directives and Standards

We hereby declare that this product meets and complies with the relevant regulations and requirements of the following directives and standards:

2006/42/EC, 2000/14/EC, 2005/88/EC, 2004/108/EC, EN 500-1, EN 500-4

Authorized Person for Technical Documents

Leo Goeschka, Wacker Neuson Produktion GmbH & Co. KG, Preußenstraße 41,
80809 München

Menomonee Falls, WI, USA, 20.02.2015

Keith Herr
Managing Director
For Wacker Neuson

Dan Domanski
Technical Director
For Wacker Neuson

Paul Sina
Manager, Product Engineering
For Wacker Neuson

Foreword	3
EC Declaration of conformity	7
EC Declaration of conformity	9
1 Safety Information	15
1.1 Signal Words Used in this Manual	15
1.2 Machine Description and Intended Use	16
1.3 Safety Guidelines for Operating the Machine	17
1.4 Service Safety	19
1.5 Operator Safety while Using Internal Combustion Engines	21
1.6 Hydraulic Fluid Safety	22
1.7 Safety Guidelines for Lifting the Machine	22
2 Labels	24
2.1 Label Locations	24
2.2 Label Meanings	26
3 Lifting and Transporting	35
3.1 Articulated Joint Locking Bar	35
3.2 Lifting the Machine	36
3.3 Tying Down and Transporting the Machine	37
4 Operation	39
4.1 Preparing the Machine for First Use	39
4.2 Control / Component Locations—Kohler	40
4.3 Control / Component Descriptions—Kohler	41
4.4 Control / Component Locations—Kubota	42
4.5 Control / Component Descriptions—Kubota	43
4.6 Features and Controls	44
4.7 Accessing the Engine or Hydraulic Component Compartments	45
4.8 Accessing the Control Compartment	45
4.9 Control Panel	46
4.10 SmartControl™ SC-3 Transmitter	48
4.11 Operating Status Indicator Codes	50
4.12 Light Ring Color Codes	52

4.13	Infra-red System and Control Channels	53
4.14	Position of the Operator	55
4.15	Range Limits	56
4.16	Operating Characteristics	57
4.17	Communication Faults	57
4.18	Machine Stability	58
4.19	Operating on Slopes	59
4.20	Rollovers	59
4.21	Refueling the Machine	60
4.22	Before Starting	61
4.23	Starting, Operating, and Stopping the Machine	62
4.24	Emergency Shutdown Procedure	65
4.25	NiMH Battery	66
4.26	Replacing the Battery Pack	66
4.27	Charging the Transmitter Battery	67
5	Engine Control Module (ECM) Diagnostics	69
5.1	Overview of the ECM and the Diagnostic Tool	69
5.2	ECM Stages of Engine Start Up	70
5.3	ECM Monitoring of Solenoids—Kohler Engine Only	71
5.4	ECM Monitoring of Solenoids—Kubota Engine Only	72
5.5	Connecting the Diagnostic Tool—Kohler Engine Only	74
5.6	Connecting the Diagnostic Tool—Kubota Engine Only	75
5.7	Programming the ECM Tip-Over Mode	76
5.8	Entering the ECM Diagnostic Mode	77
5.9	ECM Fault and Error Codes	78
5.10	Resetting the ECM Diagnostic Data and the Tip-Over Light	80
5.11	Calibrating the Joysticks	81
6	Changing Drums (RTx-SC3)	83
6.1	Removing the Drum Extensions	83
6.2	Installing Drum Extensions	85
7	General Maintenance	88
7.1	Periodic Maintenance Schedule	88
7.2	Hydraulic Oil Requirements	89
7.3	Checking the Hydraulic Oil Level	90
7.4	Changing Hydraulic Oil and Filter	91

7.5	Lubricating the Articulated Joint and Steering Cylinders	93
7.6	Cleaning SmartControl™ Transmitter	94
7.7	Scraper Bars	95
7.8	Shock Mounts	95
7.9	Maintaining the Battery	96
7.10	Draining the Fuel Filter Water Separator—Kohler Engine Only	97
7.11	Maintaining the Fuel Filter Water Separator—Kubota Engine Only ...	98
7.12	Priming the Fuel System—Kohler Engine Only	99
7.13	Storage	100
7.14	Long-Term Storage	101
7.15	Machine Disposal / Decommissioning	102
8	Engine Maintenance: Kohler (T4f)	103
9	Engine Maintenance: Kubota D902	107
10	Troubleshooting	110
11	Technical Data	113
11.1	Engine	113
11.2	Roller	114
11.3	Lubrication	114
11.4	Sound and Vibration Specifications	115
11.5	Dimensions	115
11.6	Radiation Compliance	115
12	Emission Control Systems Information and Warranty—Diesel	117
12.1	Emission Control System Background Information	117
12.2	Limited Defect Warranty for Exhaust Emission Control System	118
12.3	Limited Defect Warranty for Wacker Neuson Emission Control Systems	118
13	AEM Safety Manual	121
14	Schematics	143
14.1	Electrical Schematic—Complete—Kohler	144
14.2	Electrical Schematic Components—Kohler	145

14.3	Electrical Schematic Section A—Kohler	146
14.4	Electrical Schematic Components—Kohler	147
14.5	Electrical Schematic Section B—Kohler	148
14.6	Electrical Schematic Components—Kohler	149
14.7	Electrical Schematic Section C—Kohler	150
14.8	Electrical Schematic Components—Kohler	151
14.9	Electrical Schematic Section D—Kohler	152
14.10	Electrical Schematic Components—Kohler	153
14.11	Electrical Schematic—Complete—Kubota	154
14.12	Electrical Schematic Components—Kubota	155
14.13	Electrical Schematic Section A—Kubota	156
14.14	Electrical Schematic Components—Kubota	157
14.15	Electrical Schematic Section B—Kubota	158
14.16	Electrical Schematic Components—Kubota	159
14.17	Electrical Schematic Section C—Kubota	160
14.18	Electrical Schematic Components—Kubota	161
14.19	Electrical Schematic Section D—Kubota	162
14.20	Electrical Schematic Components—Kubota	163
14.21	Hydraulic Schematic	164
14.22	Hydraulic Schematic Components	165

1 Safety Information

1.1 Signal Words Used in this Manual

This manual contains DANGER, WARNING, CAUTION, *NOTICE*, and NOTE signal words which must be followed to reduce the possibility of personal injury, damage to the equipment, or improper service.



This is the safety alert symbol. It is used to alert you to potential personal hazards.

- ▶ Obey all safety messages that follow this symbol.



DANGER

DANGER indicates a hazardous situation which, if not avoided, will result in death or serious injury.

- ▶ To avoid death or serious injury from this type of hazard, obey all safety messages that follow this signal word.



WARNING

WARNING indicates a hazardous situation which, if not avoided, could result in death or serious injury.

- ▶ To avoid possible death or serious injury from this type of hazard, obey all safety messages that follow this signal word.



CAUTION

CAUTION indicates a hazardous situation which, if not avoided, could result in minor or moderate injury.

- ▶ To avoid possible minor or moderate injury from this type of hazard, obey all safety messages that follow this signal word.

NOTICE: Used without the safety alert symbol, NOTICE indicates a situation which, if not avoided, could result in property damage.

Note: A Note contains additional information important to a procedure.

1.2 Machine Description and Intended Use

This machine is a remote-controlled trench roller. The Wacker Neuson Trench Roller consists of two distinct machine halves (front and rear) joined by an articulated joint. Each machine half includes an exciter assembly and two drums. The front half also includes a diesel engine and pumps for the hydraulic system. The rear half includes the hydraulic oil reservoir and the fuel tank. The diesel engine powers the hydraulic systems that provide machine movement and drum vibration. The operator controls all machine functions (steering, vibration, and engine start/stop) using an infra-red control system.

This machine is intended to be used for compacting sub-bases, backfill, and cohesive type soils.

This machine has been designed and built strictly for the intended use(s) described above. Using the machine for any other purpose could permanently damage the machine or seriously injure the operator or other persons in the area. Machine damage caused by misuse is not covered under warranty.

The following are some examples of misuse:

- Using the machine as a ladder, support, or work surface
 - Using the machine to carry or transport passengers or equipment
 - Using the machine to tow other machines
 - Operating the machine outside of factory specifications
 - Operating the machine in a manner inconsistent with all warnings found on the machine and in the Operator's Manual
-

This machine has been designed and built in accordance with the latest global safety standards. It has been carefully engineered to eliminate hazards as far as practicable and to increase operator safety through protective guards and labeling. However, some risks may remain even after protective measures have been taken. They are called residual risks. On this machine, they may include exposure to:

- Heat, noise, exhaust, and carbon monoxide from the engine
- Burns from hot hydraulic fluid
- Fire hazards from improper refueling techniques
- Fuel and its fumes
- Personal injury from improper lifting techniques
- Crushing hazards from improper operation and for other persons in the work zone

To protect yourself and others, make sure you thoroughly read and understand the safety information presented in this manual before operating the machine.

1.3 Safety Guidelines for Operating the Machine

Operator training

Before operating the machine:

- Read and understand the operating instructions contained in all manuals delivered with the machine.
- Familiarize yourself with the location and proper use of all controls and safety devices.
- Contact Wacker Neuson for additional training if necessary.

When operating this machine:

- Do not allow improperly trained people to operate the machine. People operating the machine must be familiar with the potential risks and hazards associated with it.

Operator qualifications

Only trained personnel are permitted to start, operate, and shut down the machine. They also must meet the following qualifications:

- have received instruction on how to properly use the machine
- are familiar with required safety devices

The machine must not be accessed or operated by:

- children
- people impaired by alcohol or drugs

Application area

Be aware of the application area.

- Keep unauthorized personnel, children, and pets away from the machine.
- Remain aware of changing positions and the movement of other equipment and personnel in the application area/job site.
- Identify whether special hazards exist in the application area, such as toxic gases, or unstable ground conditions, and take appropriate action to eliminate the special hazards before using the machine.

Be aware of the application area.

- Do not operate the machine in areas that contain flammable objects, fuels, or products that produce flammable vapors.
- Always use the SmartControl™ transmitter neck strap provided by Wacker Neuson while operating with the control cable connected. This neck strap is designed to break away so that the operator will not be dragged by the machine should the machine slide, tip, or fall.
- Always remain in visual contact with the machine at all times while operating the controls.
- Never operate multiple rollers within 20 meters (65 feet) of one another, unless you are certain that each roller and its accompanying transmitter have been set to a different control channel than the other rollers/transmitters being used within the area. Refer to section *Setting Control Channels* for additional information.

Safety devices, controls, and attachments

Only operate the machine when:

- All safety devices and guards are in place and in working order.
- All controls operate correctly.
- The machine is set up correctly according to the instructions in the Operator's Manual.
- The machine is clean.
- The machine's labels are legible.

To ensure safe operation of the machine:

- Do not operate the machine if any safety devices or guards are missing or inoperative.
- Do not modify or defeat the safety devices.
- Only use accessories or attachments that are approved by Wacker Neuson.

-
- Use caution when operating near the edges of pits, trenches or platforms. Check to be sure that the ground surface is stable enough to support the weight of the machine with the operator and that there is no danger of the roller sliding, falling, or tipping.
 - Position yourself safely when operating machine in reverse or on hills. Leave enough space between yourself and the machine so you will not be placed in a hazardous position should the machine slide or tip.
 - Do not use a cellphone or send text messages while operating this machine.
 - Stay clear of the articulated steering joint and the area between the front and rear frames.
 - Do not consume the operating fluids used in this machine. Depending on your machine model, these operating fluids may include water, wetting agents, fuel (gasoline, diesel, kerosene, propane, or natural gas), oil, coolant, hydraulic fluid, heat transfer fluid (propylene glycol with additives), battery acid, or grease.
-

Personal Protective Equipment (PPE)

Wear the following Personal Protective Equipment (PPE) while operating this machine:

- Close-fitting work clothes that do not hinder movement
- Safety glasses with side shields
- Hearing protection
- Safety-toed footwear

1.4 Service Safety

Service training

Before servicing or maintaining the machine:

- Read and understand the instructions contained in all manuals delivered with the machine.
- Familiarize yourself with the location and proper use of all controls and safety devices.
- Only trained personnel shall troubleshoot or repair problems occurring with the machine.
- Contact Wacker Neuson for additional training if necessary.

When servicing or maintaining this machine:

- Do not allow improperly trained people to service or maintain the machine. Personnel servicing or maintaining the machine must be familiar with the associated potential risks and hazards.
-

Precautions

Follow the precautions below when servicing or maintaining the machine.

- Read and understand the service procedures before performing any service to the machine.
 - All adjustments and repairs must be completed before operating the machine. Do not operate the machine with a known problem or deficiency.
 - All repairs and adjustments shall be completed by a qualified technician.
 - Turn off the machine before performing maintenance or making repairs.
 - Remain aware of the machine's moving parts. Keep hands, feet, and loose clothing away from the machine's moving parts.
 - Re-install the safety devices and guards after repair and maintenance procedures are complete.
 - Always secure the articulated steering joint using the locking bar before lifting, jacking, and servicing the machine. The machine halves could swing together unexpectedly and cause a serious injury.
 - Do not remove the radiator cap when the engine is running or hot. The radiator fluid is hot and under pressure and may cause severe burns!
 - Do not remove air cleaner cover, paper element, or precleaner while engine is running.
 - Do not leave SmartControl™ transmitter unattended while servicing machine.
-

Machine modifications

When servicing or maintaining the machine:

- Use only accessories/attachments that are approved by Wacker Neuson.

When servicing or maintaining the machine:

- Do not defeat safety devices.
- Do not modify the machine without the express written approval of Wacker Neuson.

Replacing parts and labels

- Replace worn or damaged components.
 - Replace all missing and hard-to-read labels.
 - When replacing electrical components, use components that are identical in rating and performance to the original components.
 - When replacement parts are required for this machine, use only Wacker Neuson replacement parts or those parts equivalent to the original in all types of specifications, such as physical dimensions, type, strength, and material.
-

Cleaning

When cleaning and servicing the machine:

- Keep the machine clean and free of debris such as leaves, paper, cartons, etc.
- Keep the labels legible.

When cleaning the machine:

- Do not clean the machine while it is running.
 - Never use gasoline or other types of fuels or flammable solvents to clean the machine. Fumes from fuels and solvents can become explosive.
-

Personal Protective Equipment (PPE)

Wear the following Personal Protective Equipment (PPE) while servicing or maintaining this machine:

- Close-fitting work clothes that do not hinder movement
- Safety glasses with side shields
- Hearing protection
- Safety-toed footwear

In addition, before servicing or maintaining the machine:

- Tie back long hair.
 - Remove all jewelry (including rings).
-

After use

- Stop the engine when the machine is not being operated.
- Close the fuel valve on engines equipped with one when the machine is not being operated.
- Ensure that the machine will not tip over, roll, slide, or fall when not being operated.
- Store the machine properly when it is not being used. The machine should be stored in a clean, dry location out of the reach of children.

1.5 Operator Safety while Using Internal Combustion Engines



WARNING

Internal combustion engines present special hazards during operation and fueling. Failure to follow the warnings and safety standards could result in severe injury or death.

- ▶ Read and follow the warning instructions in the engine owner's manual and the safety guidelines below.



DANGER

Exhaust gas from the engine contains carbon monoxide, a deadly poison. Exposure to carbon monoxide can kill you in minutes.

- ▶ NEVER operate the machine inside an enclosed area, such as a tunnel, unless adequate ventilation is provided through such items as exhaust fans or hoses.

Operating safety

When running the engine:

- Keep the area around exhaust pipe free of flammable materials.
- Check the fuel lines and the fuel tank for leaks and cracks before starting the engine. Do not run the machine if fuel leaks are present or the fuel lines are loose.

When running the engine:

- Do not smoke while operating the machine.
- Do not run the engine near sparks or open flames.
- Do not touch the engine or muffler while the engine is running or immediately after it has been turned off.
- Do not operate a machine when its fuel cap is loose or missing.
- Do not start the engine if fuel has spilled or a fuel odor is present. Move the machine away from the spill and wipe the machine dry before starting.

Refueling safety

When refueling the engine:

- Clean up any spilled fuel immediately.
- Refill the fuel tank in a well-ventilated area.
- Re-install the fuel tank cap after refueling.
- Use suitable tools for refueling (for example, a fuel hose or funnel).

When refueling the engine:

- Do not smoke.
- Do not refuel a hot or running engine.
- Do not refuel the engine near sparks or open flames.

1.6 Hydraulic Fluid Safety



WARNING

Possibility of severe injury. Hydraulic fluid is under high pressure and becomes very hot during operation.

- ▶ To avoid injury, obey the safety instructions listed below.

Safety instructions

- Inspect the hydraulic system thoroughly before operating the machine.
- Do not touch hydraulic fluid or hydraulic components while the machine is operating. Wait until the machine is cool.
- Before disconnecting hydraulic fittings or hoses, ensure that all pressure has been bled from the circuit. Set all controls in neutral, turn engine off, and allow the fluids to cool before loosening hydraulic fittings or attaching test gauges.
- Hydraulic fluid escaping under high pressure may penetrate the skin, cause burns, blind, or cause other serious injuries or infections. Contact a physician immediately for treatment if your skin has been penetrated by hydraulic fluid, even if the wound seems minor.
- Fluid leaks from small holes are often practically invisible. Do not use your bare hands to check for leaks. Check for leaks using a piece of cardboard or wood.
- Hydraulic fluid is extremely flammable. Stop the engine immediately if a hydraulic leak is detected.
- After servicing the hydraulics, make sure all components are reconnected to the proper fittings. Failure to do so may result in damage to the machine and/or injury to a person on or near the machine.

1.7 Safety Guidelines for Lifting the Machine

When lifting the machine:

- Make sure slings, chains, hooks, ramps, jacks, forklifts, cranes, hoists, and any other type of lifting device used is attached securely and has enough weight-bearing capacity to lift or hold the machine safely. See section *Technical Data* for machine weight.
- Remain aware of the location of other people when lifting the machine.
- Only use the lifting points and tie-downs described in the Operator's Manual.
- Make sure the transporting vehicle has sufficient load capacity and platform size to safely transport the machine.

To reduce the possibility of injury:

- Do not stand under the machine while it is being lifted or moved.
- Do not get onto the machine while it is being lifted or moved.

Notes



2 Labels

2.1 Label Locations

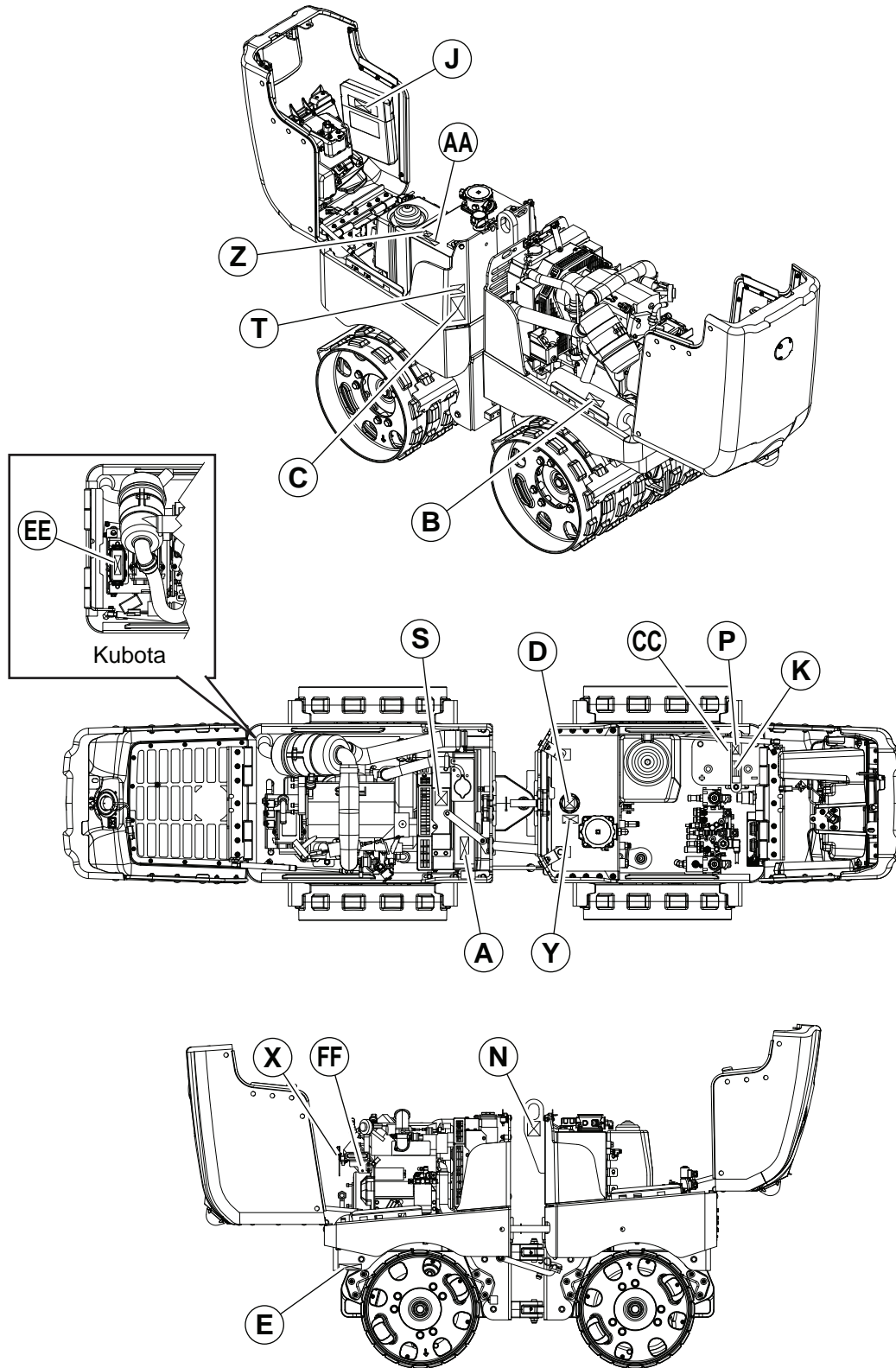



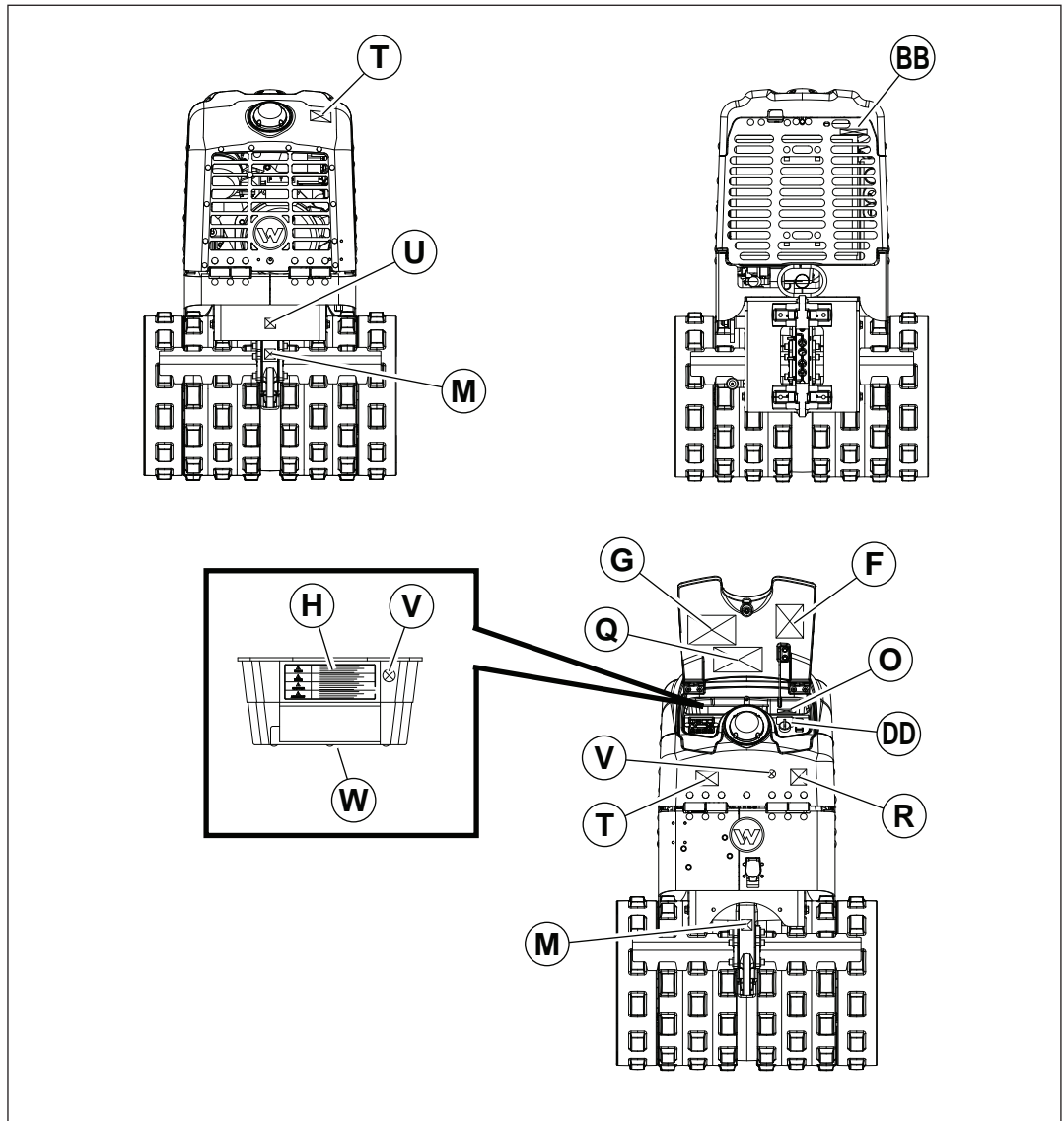



wc_gr012206



wc_gr012207

2.2 Label Meanings

<p>A</p>	 <p>110164</p>  <p>178711</p>	<p>WARNING Pressurized contents. Do not open when hot!</p>
<p>B</p>	 <p>115415</p>  <p>178729</p>	<p>WARNING Hot surface</p>
<p>C</p>	 <p>110178</p>  <p>178710</p>	<p>WARNING Pinch point.</p>
<p>D</p>	 <p>111760</p>	<p>Hydraulic oil reservoir fill</p>

<p>E</p>		<p>Radiator/Engine Oil</p>
<p>F</p>		<p>DANGER</p> <p>Asphyxiation hazard.</p> <ul style="list-style-type: none"> Engines emit carbon monoxide. Do not run the machine indoors or in an enclosed area unless adequate ventilation, through such items as exhaust fans or hoses, is provided. Read and understand the supplied Operator's Manual before operating the machine. Failure to do so increases the risk of injury to yourself or others. To reduce the risk of hearing loss, always wear hearing protection when operating this machine.

G

5200022204

▲ WARNING
 INFRARED SIGNAL: ALWAYS AIM TRANSMITTER DIRECTLY AT RECEIVING EYES ON MACHINE.
 1. NO FORWARD/REVERSE TRAVEL WITHIN 2 METERS (6.6 FEET).
 2. MACHINE MAY RECEIVE STRAY SIGNALS IF OPERATED NEAR SOLID OBJECTS.

▲ ADVERTENCIA
 SEÑAL INFRAROJA: APUNTE SIEMPRE LA UNIDAD TRANSMISORA EN DIRECCION DEL OJO RECEPTOR UBICADO EN LA MAQUINA.
 1. NO HABRA MARCHA HACIA ADELANTE O HACIA ATRAS A MENOS DE 2m.
 2. LA MAQUINA PODRA RECIBIR SEÑALES DISPERSAS AL SER OPERADA EN LAS CERCANIAS DE OBJETOS SÓLIDOS.

▲ AVERTISSEMENT
 SIGNAL A INFRAROUGE: TOUJOURS POINTER L'EMETTEUR DIRECTEMENT A LA CELLULE RECEPTRICE AU SOMMET DE LA MACHINE.
 1. MARCHÉ AVANT OU ARRIERE N'EST PAS POSSIBLE A MOINS DE 2m.
 2. C'EST POSSIBLE QUE LA MACHINE RECOTE LES SIGNAUX PERDUS SI UTILISEE DANS LE VOISINAGE DES OBJETS SOLIDES.

5200022218

WARNING

Infrared signal: Always aim transmitter directly at receiving eye on machine.

1. No travel when operator is within 2 meter (6.6 ft.) of front or rear of machine. Machine will operate when operator is within 2 meter (6.6 ft.) of either side of machine.
2. Machine may receive and react to signals reflected off objects.

Read the Operator's Manual.

H

▲ WARNING	To avoid blocking infrared transmissions and possible machine malfunctions, do not attach labels to housing! Clean transmitter and receiving eyes before using! To avoid being pulled by the cable, use only Wacker Neuson breakaway neck strap!
▲ WARNING	Um Störungen der Infrarot-Übertragung und mögliche Maschinen-Fehlfunktionen zu vermeiden, darf keine Beschriftung an der Maschine angebracht werden! Reinigen Sie die Infrarot-Emitter und Empfänger vor dem Gebrauch! Um einen Sturz durch das Seil zu vermeiden, verwenden Sie ausschließlich die Kettenschnalle von Wacker Neuson!
▲ ADVERTENCIA	Para evitar interferencias en la transmisión infrarroja y posibles fallos en el funcionamiento de la máquina, no se debe colocar etiquetas en el alojamiento. Limpiar el emisor y el receptor antes de la puesta en marcha. Evitar el riesgo de caídas por el uso del cable. Utilice sólo la correa de seguridad Wacker Neuson.
▲ AVERTISSEMENT	Pour éviter les pertes de données lors de la transmission infrarouge et de possibles dysfonctionnements de machines, ne rien coller sur le boîtier. Aviser de même avant de mettre le levier et le câble dans leur usage. Pour éviter une chute ou d'être tiraillé, utiliser uniquement la sangle Wacker Neuson.

▲ WARNING	Clean transmitter and receiving eyes before using!
▲ WARNING	Vor Infrarotstrahlung: Reinigen Sie Emitter und Empfänger vor dem Gebrauch!
▲ ADVERTENCIA	Limpiar los ojos de transmisión y recepción antes de usar!
▲ AVERTISSEMENT	Nettoyer le transmetteur et le récepteur avant utilisation!
▲ AVVERTENZA	Pulire le visor del trasmettitore e del ricevitore prima dell'uso!
▲ WAARSCHUWING	Maak vóór gebruik de lenzen en ontvangers schoon!
▲ ADVARSEL	Renset senderne og modtagerne før brug!
▲ VAROITUS	Puhdista lähettävät ja vastaanottavat ennen käyttöönottoa!

To avoid blocking infrared transmissions and possible machine malfunctions, do not attach labels to housing!
Clean transmitter and receiving eyes before using!
To avoid being pulled by the cable, use only Wacker Neuson breakaway neck strap!

Clean transmitter and receiving eyes before using!

Read the Operator's Manual.

J

OPERATOR'S MANUAL MUST BE STORED ON MACHINE. REPLACEMENT OPERATOR'S MANUAL CAN BE ORDERED THROUGH YOUR LOCAL WACKER DISTRIBUTOR.

EL MANUAL DE OPERACION DEBE SER RETENIDO EN LA MAQUINA. CONTACTE A SU DISTRIBUIDOR WACKER MAS CERCANO PARA PEDIR UN EJEMPLAR ADICIONAL.





LA NOTICE D'EMPLOI DOIT ETRE MUNIE SUR LA MACHINE. CONTACTER LE DISTRIBUTEUR WACKER LE PLUS PROCHE POUR COMMANDER UN EXEMPLAIRE SUPPLEMENTAIRE.

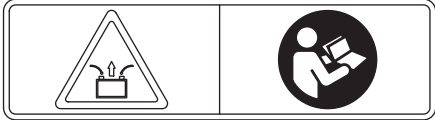

115096

www.wackerneuson.com

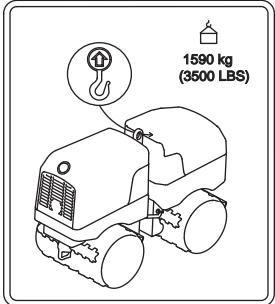
180562

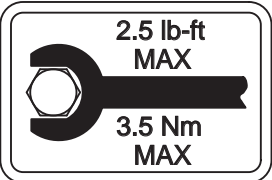

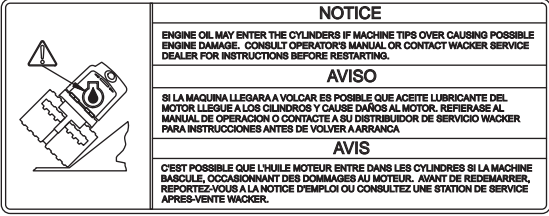
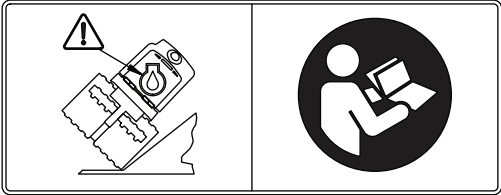

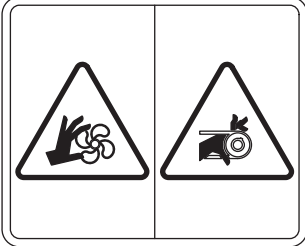

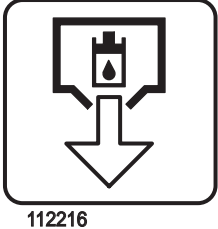
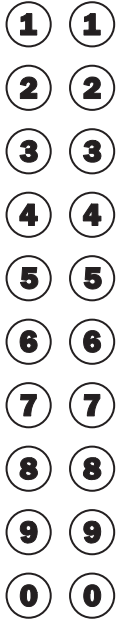





Operator's Manual must be stored on machine. Replacement Operator's Manual can be ordered through your local Wacker Neuson distributor.

<p>K</p>	 <p>114891</p>  <p>178730</p>	<p>WARNING Disconnect battery before servicing. Read the Operator's Manual.</p>
<p>M</p>	 <p>113726</p>	<p>Tie-down point</p>
<p>N</p>	 <p>620013414</p>	<p>NOTICE Lifting point</p>
<p>O</p>	 <p>159114</p>	<p>This machine may be covered by one or more patents.</p>
<p>P</p>	 <p>115682</p>	<p>Torque battery hold-down nuts to 3.5 Nm (2.5 ft.lbs.) max.</p>

<p>Q</p>	 <p>176194</p>  <p>178824</p>	<p>NOTICE Engine oil may enter the cylinders if machine tips over, causing possible engine damage. Consult Operator's Manual or contact your Wacker Neuson Service Dealer for instructions before restarting.</p>
<p>R</p>		<p>Guaranteed sound power level in dB(A)</p>
<p>S</p>	 <p>159850</p>  <p>178717</p>	<p>WARNING Entanglement hazard. Rotating machinery. Do not reach inside machine when engine is running.</p>

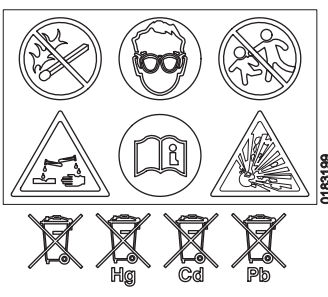
<p>T</p>		<p>CAUTION Do not stand within 2m (6.6 ft.) of the machine when the amber control lights are flashing. The roller will respond to remote signals when the light is flashing.</p>
<p>U</p>		<p>Hydraulic oil drain</p>
<p>V</p>		<p>Channel labels: Mark the operating channel on both the transmitter and roller. Replace original label with new when channels are changed.</p>

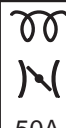
<p>W</p>	<table border="1"> <tr> <td style="text-align: center;">▲ CAUTION</td> <td>To avoid unintended operation when using multiple machines, select different channel settings for each machine ! To avoid transmitter damage and possible malfunction, do not open housing ! See Operator's Manual.</td> </tr> <tr> <td style="text-align: center;">▲ VORSICHT</td> <td>Um unkontrolliertes Fahren bei Benutzung mehrerer Maschinen zu vermeiden; unterschiedliche Kanaladressen wählen ! Um Beschädigungen und mögliche Fehlfunktionen des Senders zu vermeiden; Gehäusenicht öffnen ! Siehe Betriebsanleitung!</td> </tr> <tr> <td style="text-align: center;">▲ ATENCIÓN</td> <td>Para evitar una operación descontrolada durante uso de varias máquinas; seleccione un canal diferente para cada máquina ! Para evitar daños y posibles fallos del transmisor; no abra la caja del transmisor ! Vea el manual de operación !</td> </tr> <tr> <td style="text-align: center;">▲ ATTENTION</td> <td>Pour éviter la conduite incontrôlée lors de l'utilisation de plusieurs machines; sélectionner différents canaux ! Pour éviter des détériorations et de possibles dysfonctionnements de l'émetteur; ne pas ouvrir le boîtier ! Voir la notice d'utilisation !</td> </tr> </table>	▲ CAUTION	To avoid unintended operation when using multiple machines, select different channel settings for each machine ! To avoid transmitter damage and possible malfunction, do not open housing ! See Operator's Manual.	▲ VORSICHT	Um unkontrolliertes Fahren bei Benutzung mehrerer Maschinen zu vermeiden; unterschiedliche Kanaladressen wählen ! Um Beschädigungen und mögliche Fehlfunktionen des Senders zu vermeiden; Gehäusenicht öffnen ! Siehe Betriebsanleitung!	▲ ATENCIÓN	Para evitar una operación descontrolada durante uso de varias máquinas; seleccione un canal diferente para cada máquina ! Para evitar daños y posibles fallos del transmisor; no abra la caja del transmisor ! Vea el manual de operación !	▲ ATTENTION	Pour éviter la conduite incontrôlée lors de l'utilisation de plusieurs machines; sélectionner différents canaux ! Pour éviter des détériorations et de possibles dysfonctionnements de l'émetteur; ne pas ouvrir le boîtier ! Voir la notice d'utilisation !	<p>To avoid unintended operation when using multiple machines, select different channel settings for each machine! To avoid transmitter damage and possible malfunction, do not open housing! See Operator's Manual!</p>						
▲ CAUTION	To avoid unintended operation when using multiple machines, select different channel settings for each machine ! To avoid transmitter damage and possible malfunction, do not open housing ! See Operator's Manual.															
▲ VORSICHT	Um unkontrolliertes Fahren bei Benutzung mehrerer Maschinen zu vermeiden; unterschiedliche Kanaladressen wählen ! Um Beschädigungen und mögliche Fehlfunktionen des Senders zu vermeiden; Gehäusenicht öffnen ! Siehe Betriebsanleitung!															
▲ ATENCIÓN	Para evitar una operación descontrolada durante uso de varias máquinas; seleccione un canal diferente para cada máquina ! Para evitar daños y posibles fallos del transmisor; no abra la caja del transmisor ! Vea el manual de operación !															
▲ ATTENTION	Pour éviter la conduite incontrôlée lors de l'utilisation de plusieurs machines; sélectionner différents canaux ! Pour éviter des détériorations et de possibles dysfonctionnements de l'émetteur; ne pas ouvrir le boîtier ! Voir la notice d'utilisation !															
<p>X</p>	<div style="border: 1px solid black; padding: 10px; text-align: center;"> <p style="font-size: 2em; letter-spacing: 1em;">P T G</p> <p>165346</p> </div>	<p>P=Power relay T= Throttle relay G= Glowplug relay (Kohler powered machines only)</p>														
<p>Y</p>	<div style="border: 1px solid black; padding: 5px; margin-bottom: 10px;"> <table border="1" style="display: inline-table; border-collapse: collapse;"> <tr><td style="text-align: center;">NOTICE</td></tr> <tr><td style="text-align: center;">AVISO</td></tr> <tr><td style="text-align: center;">AVIS</td></tr> </table> </div> <p>176195</p> <div style="border: 1px solid black; padding: 10px; margin-top: 10px; text-align: center;"> </div> <p>0178728</p>	NOTICE	AVISO	AVIS	<p>Hydraulic oil reservoir fill</p>											
NOTICE																
AVISO																
AVIS																
<p>Z</p>	<div style="border: 1px solid black; padding: 5px; margin-bottom: 10px;"> <p style="text-align: center;">▲ DANGER</p> <table border="1" style="width: 100%; border-collapse: collapse;"> <tr> <td style="text-align: center;">▲ PELIGRO</td> <td style="text-align: center;">▲ DANGER</td> </tr> <tr> <td style="text-align: center;"></td> <td style="text-align: center;"></td> </tr> <tr> <td style="text-align: center;"></td> <td style="text-align: center;"></td> </tr> <tr> <td style="text-align: center;"></td> <td style="text-align: center;">DIESEL</td> </tr> </table> <p>119050</p> </div> <div style="border: 1px solid black; padding: 5px; margin-top: 10px;"> <table border="1" style="width: 100%; border-collapse: collapse;"> <tr> <td style="text-align: center;"></td> <td style="text-align: center;"></td> <td style="text-align: center;"></td> </tr> <tr> <td style="text-align: center;"></td> <td style="text-align: center;"></td> <td style="text-align: center;"></td> </tr> </table> <p>178715 HONDA</p> </div>	▲ PELIGRO	▲ DANGER						DIESEL							<p>DANGER Asphyxiation hazard</p> <ul style="list-style-type: none"> ■ Engines emit carbon monoxide. ■ Do not run the machine indoors or in an enclosed area unless adequate ventilation, through such items as exhaust fans or hoses, is provided. ■ Read the Operator's Manual. No sparks, flames, or burning objects near the machine. Stop the engine before refueling.
▲ PELIGRO	▲ DANGER															
	DIESEL															

<p>AA</p>	<div style="border: 1px solid black; padding: 5px; margin-bottom: 10px;"> <p>ULTRA LOW SULFUR FUEL ONLY. NUR ULTRANIEDRIGEN SCHWEFELKRAFTSTOFF. SOLAMENTE COMBUSTIBLE DE ULTRABAJO CONTENIDO DE AZUFRE. SEULEMENT CARBURANT DE SOUFRE ULTRA BAS.</p> </div> <div style="border: 1px solid black; padding: 5px; display: flex; justify-content: space-around;"> <div style="text-align: center;">  LSD-S500 <small>180563</small> </div> <div style="text-align: center;">  ULSD-S15 </div> </div>	<p>Low sulfur fuel or ultra low sulfur fuel only.</p>
<p>BB</p>	<div style="border: 1px solid black; padding: 5px; margin-bottom: 10px;"> <p>⚠WARNING ⚠ADVERTENCIA ⚠AVERTISSEMENT</p>    <p><small>5200005890</small></p> </div> <div style="border: 1px solid black; padding: 5px;">    <p><small>5200005891</small></p> </div>	<p>WARNING Explosion hazard.</p> <ul style="list-style-type: none"> ■ Do not use evaporative starting fluids such as ether on this engine. ■ The engine is equipped with a cold starting aid. Using evaporative starting fluids can cause an explosion which can cause engine damage, personal injury, or death. ■ Read and follow the engine starting instructions in this Operator's Manual.
<p>CC</p>	 <p style="text-align: right; font-size: small;"><small>0163189</small></p>	<p>WARNING</p> <ul style="list-style-type: none"> ■ Keep all sparks and open flames away from the battery. ■ Wear eye protection. ■ Keep away from children. ■ Battery acid is poisonous and corrosive. ■ Read the Operator's Manual. ■ Explosion hazard. <p>Dispose of waste batteries in accordance with local environmental regulations. Battery contains mercury (Hg), cadmium (Cd), or lead (Pb).</p>
<p>DD</p>	<div style="border: 1px solid black; padding: 10px; text-align: center;"> <p>WACKER NEUSON</p>  <p><small>5200022203</small></p> </div>	<p>Key switch, engine start: ON (I) OFF (O)</p>
<p>EE</p>	<div style="border: 1px solid black; padding: 5px; display: flex; justify-content: space-around;">     </div> <p><small>5200022183</small></p>	<p>Fuses/relays</p> <ul style="list-style-type: none"> ■ Glow plug relay ■ Glow plug and throttle 50A fuses ■ Stop solenoid 50A fuse ■ Throttle relay <p>(Kubota powered machines only)</p>

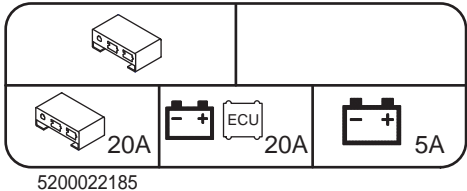
<p>FF</p>	 <p>5200022185</p>	<p>Fuse/relay block</p> <ul style="list-style-type: none"> ■ Decoder power relay ■ Decoder 20A fuse ■ ECM 20A fuse ■ Alternator 5A fuse <p>(Kubota powered machines only)</p>
-----------	---	---

3 Lifting and Transporting

3.1 Articulated Joint Locking Bar

A bar is provided to lock the articulated joint, and prevent the two machine halves from swinging together.

When lifting or jacking up the machine, secure the articulated joint with the bar as shown. Hold bar in position using the cotter pin **(a)** provided.

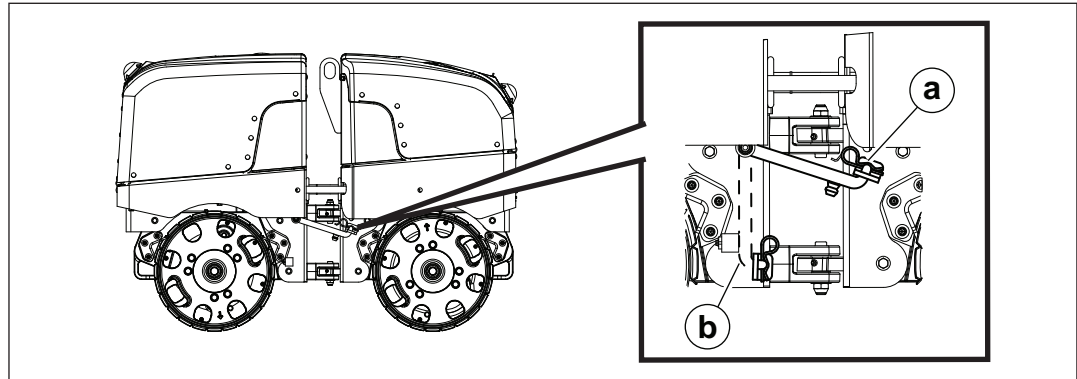

wc_gr012175

When operating the machine, place the bar in the storage clamp **(b)** as shown.

3.2 Lifting the Machine

- Requirements**
- Lifting equipment (crane or hoist) capable of supporting the machine's weight
 - Lifting hooks and chains capable of supporting the machine's weight
 - Engine stopped

Procedure A lifting eye is used for lifting the machine.

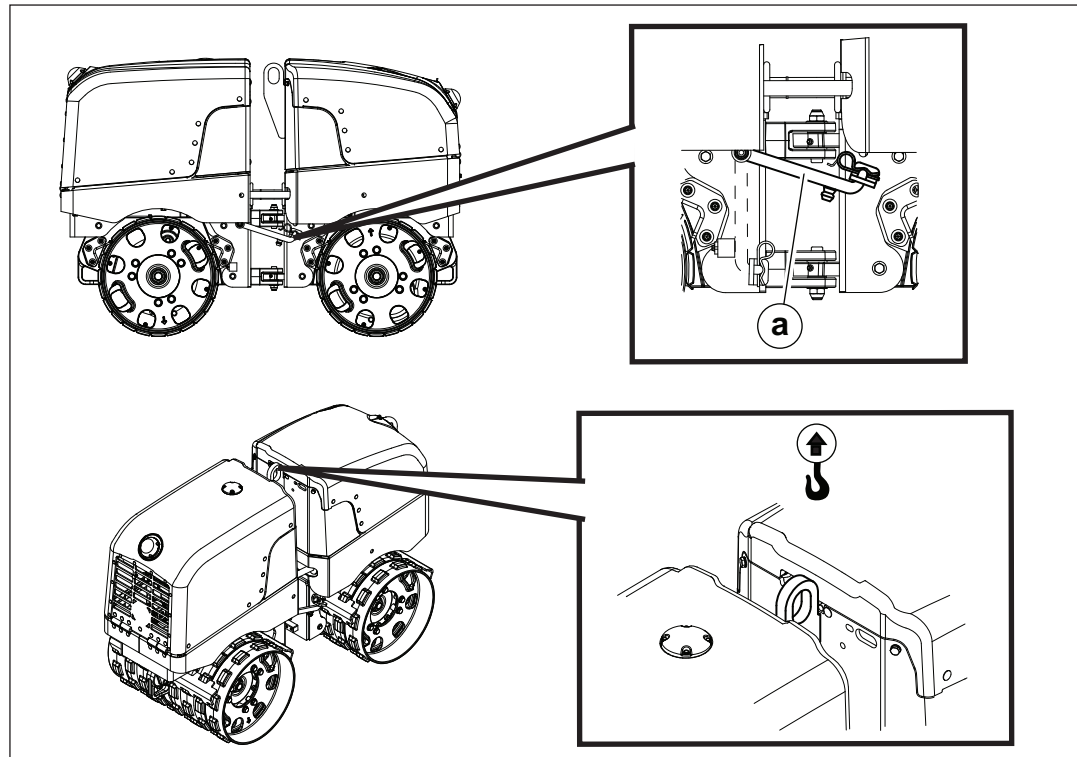

wc_gr012167

Perform the procedure below to lift the machine.

1. Lock the front and rear halves of the machine using the articulated joint locking bar **(a)**.
2. Attach the lifting devices and equipment to the lifting eye. Do not attach lifting devices to any other part of the machine.
3. Lift the machine a small distance.



WARNING

Crushing hazard. An unstable machine may cause the lifting devices and equipment to fail. You may be crushed if the lifting devices and equipment fail.

- ▶ Check for stability before continuing.

4. Check for stability. If the machine is not stable, lower it, reposition the lifting devices, and lift the machine a small distance again.
5. Continue lifting the machine as necessary.

3.3 Tying Down and Transporting the Machine

- Requirements**
- Engine shut down
 - Chocks in place
 - Steel ropes or chains

Procedure Perform the procedure below to tie down the machine.

1. Make sure that the transport vehicle is capable of handling the weight and size of the machine. See *Technical Data* for dimensions and operating weight.
2. Lock the front and rear halves of the machine using the articulated joint locking bar **(a)**.
3. Place chocks **(b)** in front of and behind each drum.

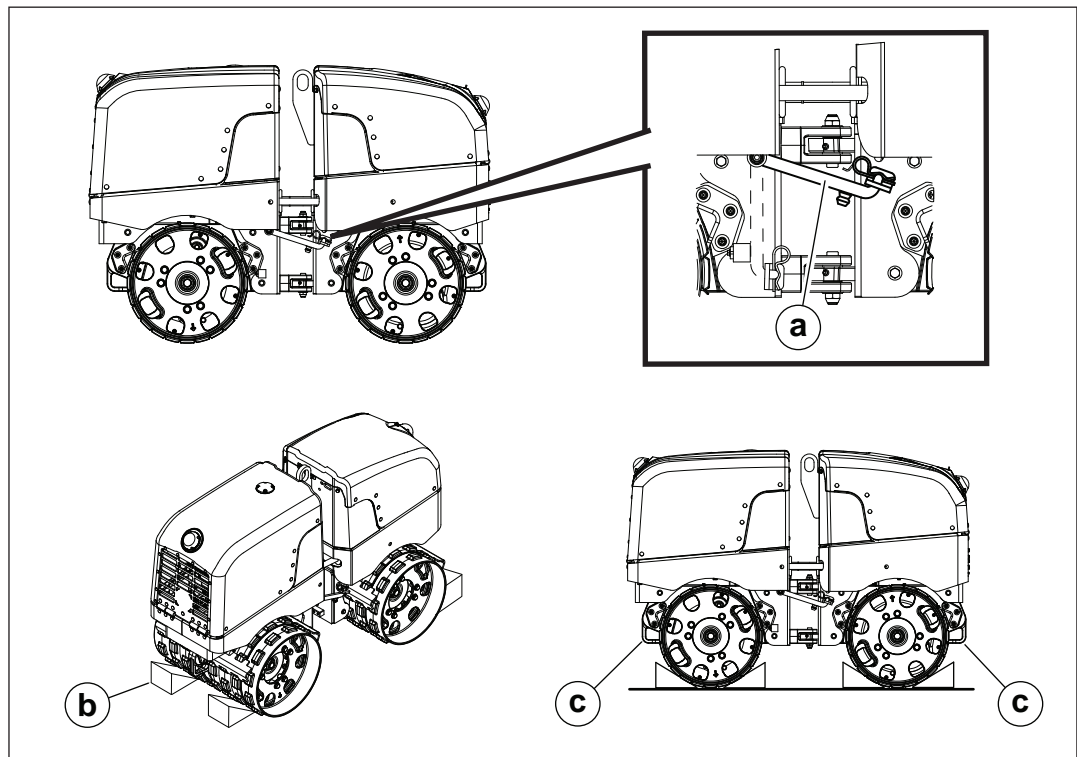

wc_gr012168

4. Attach steel ropes or chains to the front and rear tie downs **(c)**.

NOTICE: Only use the tie downs to secure the machine. Do not use any other part of the roller to tie down the machine, as severe damage to the machine may occur.

5. Attach the other end of the steel ropes or chains to the transport vehicle.

Notes

4 Operation

4.1 Preparing the Machine for First Use

1. Make sure all loose packaging materials have been removed from the machine.
2. Check the machine and its components for damage. If there is visible damage, do not operate the machine! Contact your Wacker Neuson dealer immediately for assistance.
3. Take inventory of all items included with the machine and verify that all loose components and fasteners are accounted for.
4. Attach component parts not already attached.
5. Add fluids as needed and applicable, such as fuel and engine oil.
6. Move the machine to its operating location.

4.2 Control / Component Locations—Kohler

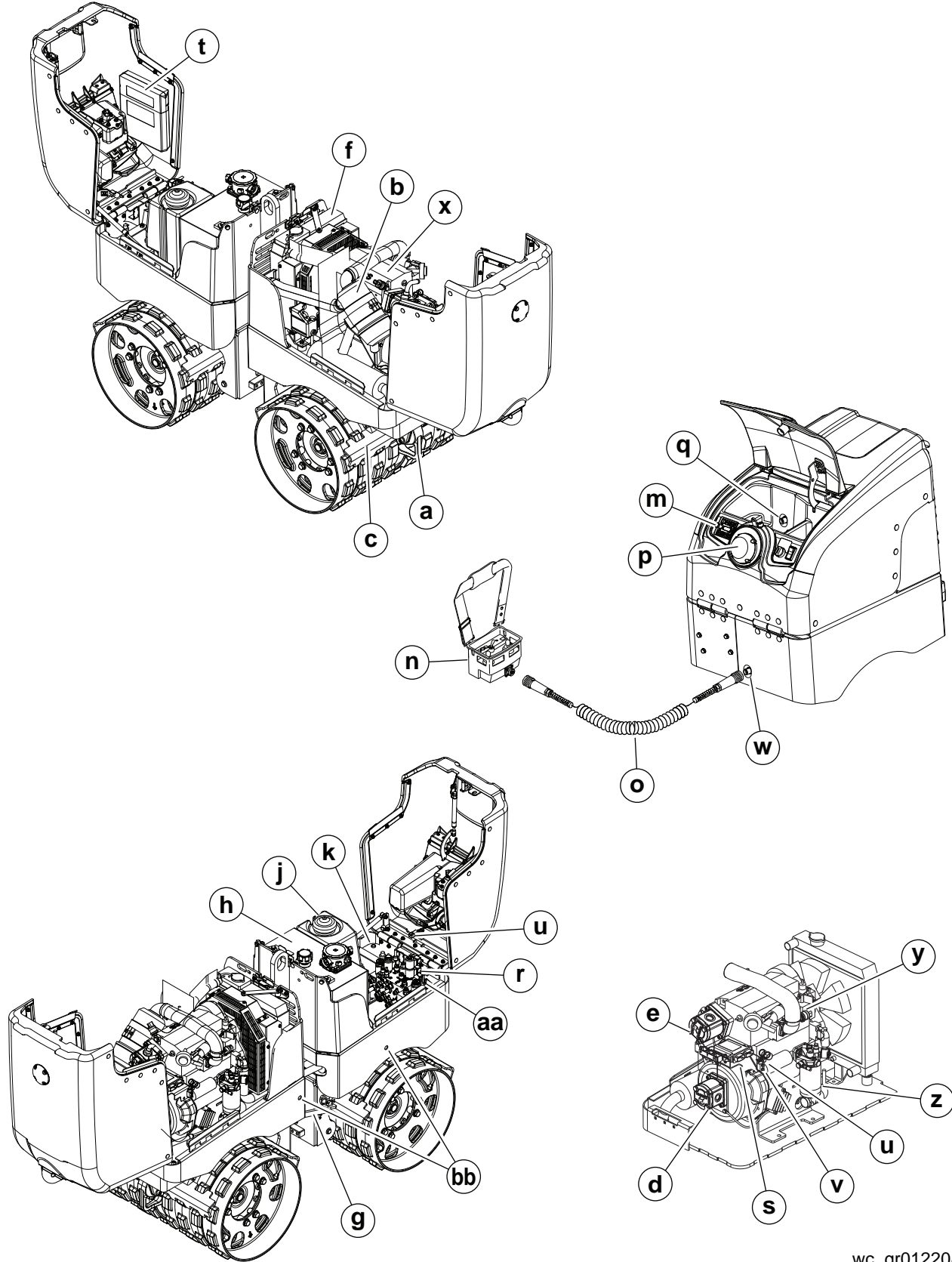

wc_gr012208

4.3 Control / Component Descriptions—Kohler

Ref.	Description	Ref.	Description
a	Tie-downs	p	Receiving eye/light ring
b	Air cleaner	q	Docking port
c	Scraper bar	r	Decoder module
d	Exciter pump	s	Engine Control Module (ECM)
e	Drive pump	t	Manual holder
f	Radiator	u	System fuse - 20A
g	Articulated joint locking bar	v	Self-resetting circuit breaker - 50A
h	Hydraulic tank	w	Charge cord / service box receptacle
j	Fuel tank	x	Oil pressure switch
k	Battery	y	Air filter restriction switch
m	Display panel	z	Fuel filter
n	SmartControl™ SC-3 transmitter	aa	Hydraulic manifold
o	Charge cable	bb	Steering cylinder grease fittings

4.4 Control / Component Locations—Kubota

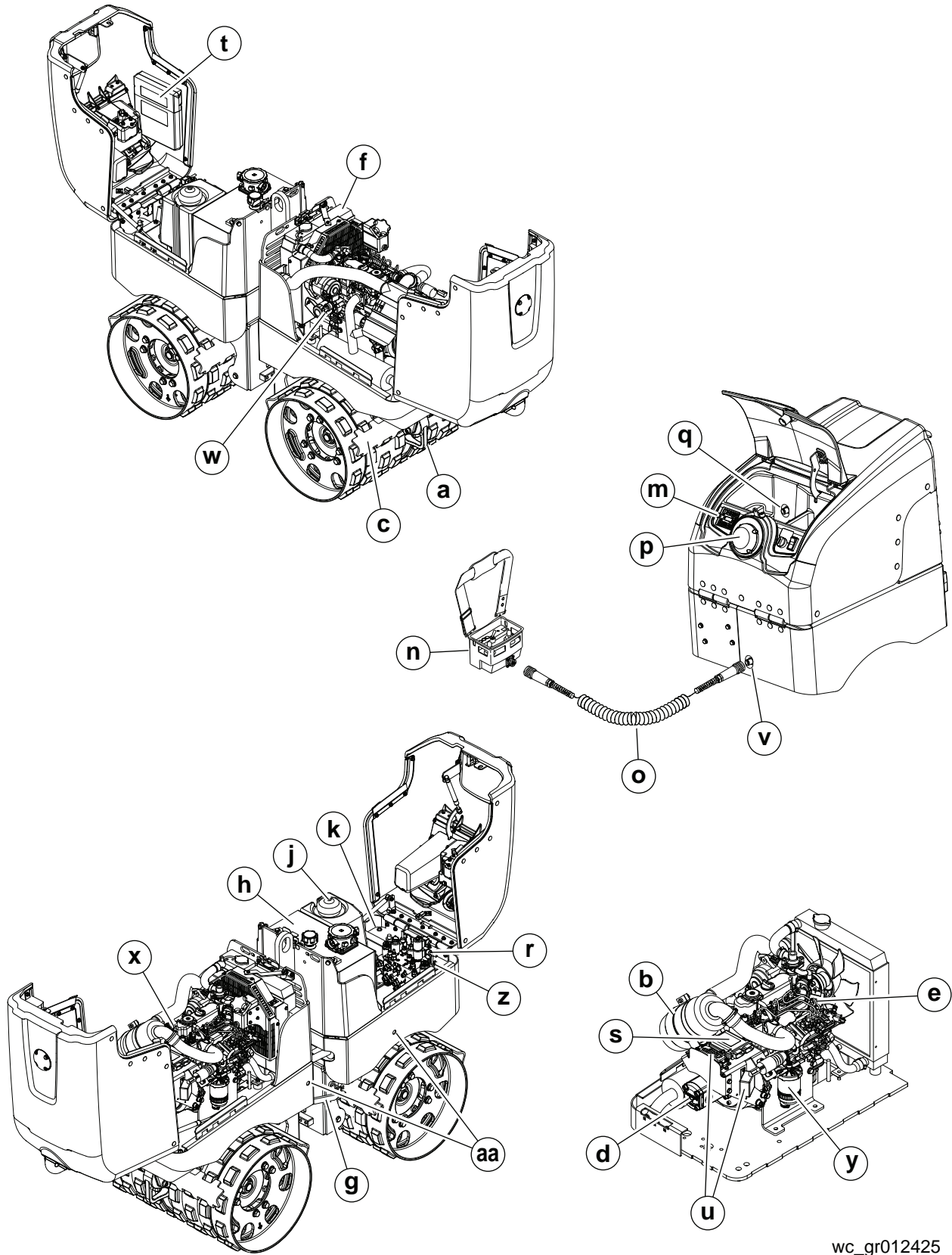

wc_gr012425

4.5 Control / Component Descriptions—Kubota

Ref.	Description	Ref.	Description
a	Tie-downs	p	Receiving eye/light ring
b	Air cleaner	q	Docking port
c	Scraper bar	r	Decoder module
d	Exciter/drive pump	s	Engine Control Module (ECM)
e	Stop solenoid	t	Manual holder
f	Radiator	u	Fuses/relays
g	Articulated joint locking bar	v	Charge cord / service box receptacle
h	Hydraulic tank	w	Oil pressure switch
j	Fuel tank	x	Air filter restriction switch
k	Battery	y	Fuel filter
m	Display panel	z	Hydraulic manifold
n	SmartControl™ SC-3 transmitter	aa	Steering cylinder grease fittings
o	Charge cable	—	—

4.6 Features and Controls

This machine is designed specifically for remote control operation. This feature protects the operator by allowing him or her to stand at a distance from the machine, and the work area, during operation. When used in excavations, it allows the operator to stand safely above the trench, rather than in it.

The SC-3 transmitter **(a)** is designed for infra-red (IR) remote-controlled operations only. The coil cord **(b)** is only used for charging the transmitter battery or supplying power to the transmitter when there is no battery. No control signals are sent through the cord.

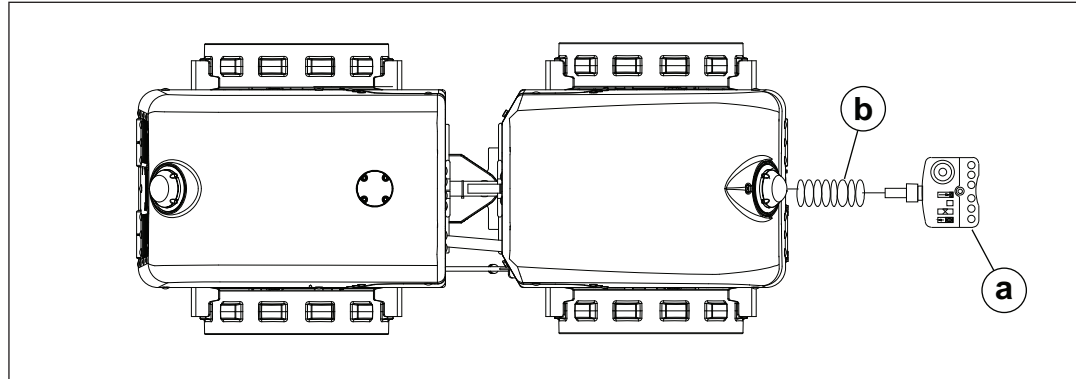

wc_gr012172

The infra-red system includes the transmitter and receiving eyes. This system provides wireless line-of-sight operation up to 20 meters (65 feet). It uses a hand-held transmitter to transmit signals to the receiving eyes on the machine to control machine operation. Only one eye needs to receive a signal for proper operation.

When operating multiple rollers within 20 meters (65 feet) of one another, it is possible that the transmitter from one roller can inadvertently take control of another roller. This can occur when multiple rollers are set to the same control channel as that of one transmitter. To prevent the transmitter from one roller inadvertently taking control of another roller, be certain that each roller and its accompanying transmitter are set to a different control channel than the other rollers/transmitters being used within the area. Refer to section *Infra-red System and Control Channels* for additional information.

4.7 Accessing the Engine or Hydraulic Component Compartments

To access the engine or hydraulic component compartments:

1. Reach into the slot in the cover and press the latch release **(a)** until the latch opens.

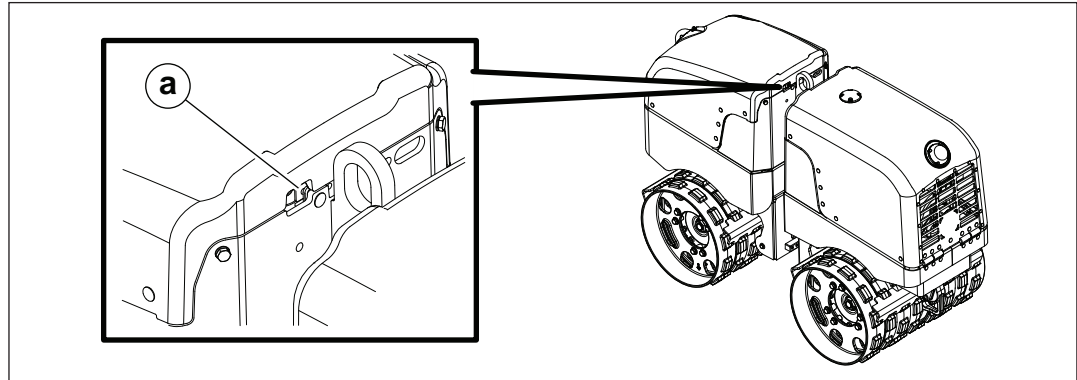

wc_gr012173

2. Raise hinged cover and place in the open position.

To close:

3. Position cover over the compartment, near the closed position.
4. Being careful not to pinch fingers or hands, release cover and allow weight of cover to engage latch.

4.8 Accessing the Control Compartment

Procedure Perform the procedure below to access the control compartment.

1. To open, pull up on both ends of the control compartment door **(a)**.

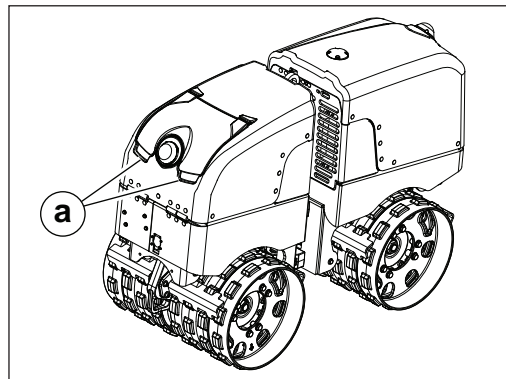

wc_gr012176

2. To close, push the control compartment door down into the closed position until the door is secured.

4.9 Control Panel

The control panel is mounted to the dash under the back hood access cover of the machine. It contains the following features:

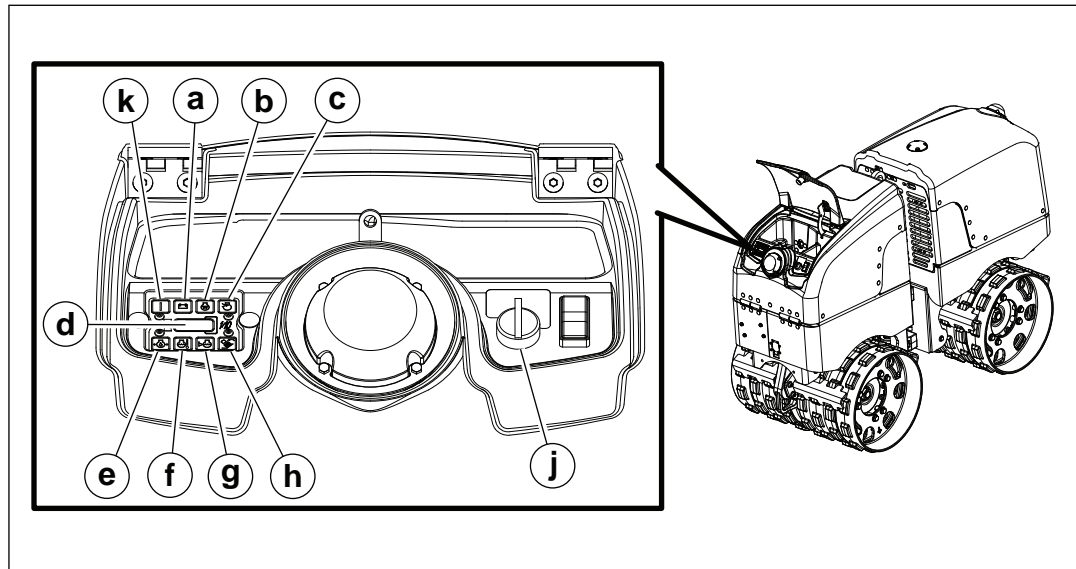

wc_gr012188

Ref.	Component	Description
a	Charging system light	The engine is equipped with an alternator and voltage regulator to maintain the battery charge. The charging system warning light illuminates when there is a malfunction of the system. Although the machine will run with the light on for a short period of time, continued operation will drain the battery and eventually cause the machine to lose all operating functions. If the system warning light illuminates while operating the machine in a narrow trench or other confined area, drive machine into a safer area as soon as possible to avoid stranding it in a hazardous or inaccessible location.
b	Glow plug light	The engine is equipped with an automatic glow plug system that pre-heats the combustion chambers to improve normal and cold weather starts. The glow plug light illuminates when the keyswitch and the transmitter ON/OFF switch are placed in the ON (I) positions. It will go off when the combustion chambers are pre-heated. Allow 5 minutes for the engine to warm up before operating the roller.
c	Air cleaner light	The air cleaner warning light illuminates when the air filter cartridge needs to be replaced.
d	Hour meter	The hour meter records the actual running time of the engine. Use the hour meter when planning scheduled maintenance.

Ref.	Component	Description
e	Engine oil pressure light	The oil pressure warning light illuminates when oil pressure falls below the engine manufacturer's recommended value. During such a condition, the engine will automatically shut down.
f	Coolant temperature light	The cooling temperature warning light illuminates when engine coolant temperature exceeds 230°F (110°C). During such a condition, the engine will automatically shut down. Allow temperature to drop below 212°F/100°C before attempting to restart.
g	Coolant level light	The cooling level warning light illuminates when coolant level is too low. During such a condition, the engine will automatically shut down.
h	Stability light	The stability warning light illuminates when the pitch of the roller exceeds 45°. The machine is equipped with safety switches that shut down the engine during such a condition.
j	Keyswitch	Turning the keyswitch to the ON (I) position supplies 12VDC power to the machine. The green power-on indicator (k) illuminates indicating power is on. The keyswitch has an automatic shutoff feature that powers off the electronics after one hour of non-engine run time. To reset the machine, turn the keyswitch to the OFF (O) position and then back to the ON (I) position. The machine can be restarted within this 1-hour period if the transmitter is turned off and then on. The glow plugs will be activated if needed. All shutdown functions have a fault detection feature where the warning light and red LED light rings remain on after the machine shuts down, until the fault is corrected, and the keyswitch is turned to the OFF (O) position. All shutdown functions and the air filter restriction circuit have built-in circuitry to detect a possible bad sensor, unplugged sensor, or a cut or damaged wire to the sensor. Whenever any of these sensor faults occur, the corresponding control panel light will flash on and off.

4.10 SmartControl™ SC-3 Transmitter

- Wireless control
- Line of sight operation
- 16 control channels
- Clear transmissions into direct sunlight, up to 130,000 LUX
- Maximum range: 20m (65 ft.)
- Transmitting time (full charge): 12 hours
- Recharge time (full charge): 2-1/2 hours
- Battery: Ni-MH (nickel metal hydride) battery pack

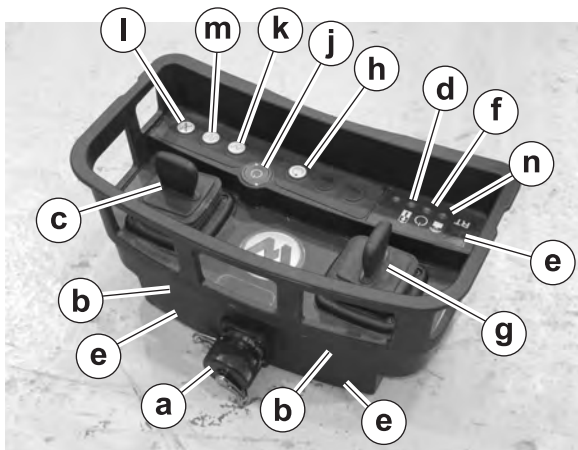

wc_gr006335

Ref	Component	Description
a	Cable connector	The cable connector provides a connection point for the transmitter cord. When the transmitter cord is connected, the transmitter battery recharges while the engine is running.
b	Infra-red emitting diodes	The diodes—located on all sides of the transmitter—are used to transmit the coded infra-red signal to the receiving eyes on the machine. Keep the transmitter clean to ensure maximum signal strength.
c	Forward/reverse (travel) joystick	The right joystick (c) controls forward/reverse motion.
g	Left/right (steering) joystick	The left joystick (g) controls left/right motion. Move the joysticks in the direction desired. The roller will change to high speed whenever the travel joystick is placed fully in the forward or fully in the reverse position.
d	Battery charge indicator	This LED illuminates green while the battery is charging.

Ref	Component	Description
e	Near field transmitting diodes (LEDs)	These LEDs—located on all sides of the transmitter—are part of the machine's sensing system which stops the machine when the operator and transmitter are located too close to the machine.
f	Operating status indicator	This LED indicates the operating status of the transmitter. <i>See Operating Status Indicator Codes.</i>
h	Engine START pushbutton	Pressing this button causes the engine to crank. An override prevents the engine from cranking if it is already running.
j	ON/OFF pushbutton	Pressing this button turns on and off the SmartControl™ transmitter. The operating status indicator (f) illuminates green (flashing) when the transmitter is on. Turning the transmitter off stops the engine and the machine.
k	LOW vibration pushbutton	Pressing this button causes the vibration to come on in the LOW vibration mode.
l	Vibration OFF pushbutton	Pressing this button causes all vibration to stop.
m	HIGH vibration pushbutton	Pressing this button causes the vibration to come on in the HIGH vibration mode.
—	Vibration pushbuttons	When the machine is moving in the high speed travel mode, pressing either vibration pushbutton (k or m) causes the roller to drop out of the high speed travel mode and into the low speed travel mode. Conversely, when the vibration is on, the machine cannot go into the high speed travel mode.
n	Signal transmission indicator	To aid in diagnostics, this green LED flashes any time a signal is sent to the roller.
o	Control channel selector switch	This selector switch, when set to match that of the machine's decoder module, allows the SmartControl to control the roller.

4.11 Operating Status Indicator Codes

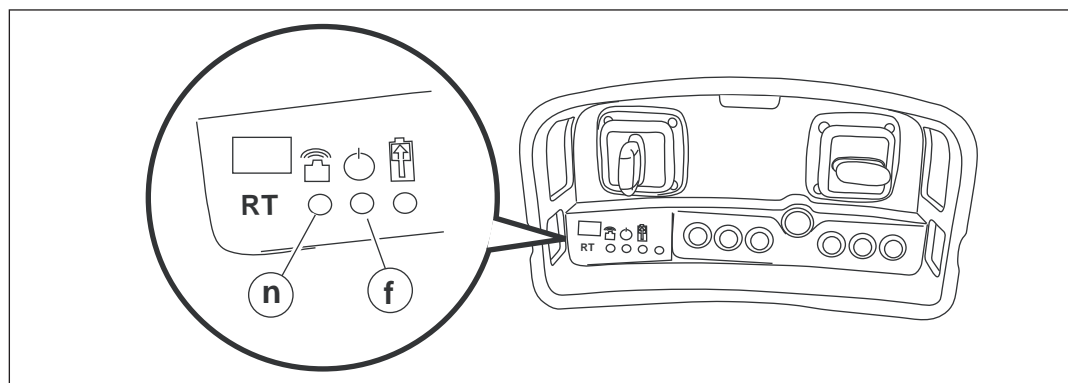

wc_gr010837

Ref.	Color and appearance	Status	Transmitter function	Cause	Remedy
f	None	Off	Off	<ul style="list-style-type: none"> ■ No power: transmitter is OFF. ■ No power: battery is discharged. 	<ul style="list-style-type: none"> ■ Turn transmitter ON. ■ Check battery.
	Green (blinking slowly)	On (normal)	Normal operation	—	—
	Green (steady)	Setup mode	Awaiting joystick calibration.	<ul style="list-style-type: none"> ■ See topic <i>Calibrating the Joysticks</i>. 	See topic <i>Calibrating the Joysticks</i> .
	Green (blinking rapidly)	Calibration mode	Transmitter is in calibration mode, and the calibration procedure can be performed.	<ul style="list-style-type: none"> ■ See <i>Calibrating the Joysticks</i>. 	See <i>Calibrating the Joysticks</i> .
	Red to green to yellow (cycling)	Most recent joystick calibration had an error.	Machine operation may still be possible depending on amount of usable data available.	<ul style="list-style-type: none"> ■ Joystick(s) incorrectly calibrated. Middle position of joystick(s) is not being detected. 	<ul style="list-style-type: none"> ■ Recalibrate joysticks.
	Red and green (alternating)	Under-voltage fault	Weak signal communication.	<ul style="list-style-type: none"> ■ Battery charge is low. 	<ul style="list-style-type: none"> ■ Recharge or replace battery.
	Red (flashing every second)	Under-voltage fault	Transmission has stopped. Transmitter unable to control the machine.	<ul style="list-style-type: none"> ■ Discharged battery. 	<ul style="list-style-type: none"> ■ Recharge or replace battery.
	Red (blinking rapidly)	Joystick calibration is required	Transmitter unable to control the machine.	<ul style="list-style-type: none"> ■ Joysticks not calibrated 	<ul style="list-style-type: none"> ■ Calibrate joysticks. ■ If calibration does not solve the problem, contact Wacker Neuson Product Support.

Ref.	Color and appearance	Status	Transmitter function	Cause	Remedy
	Red (steady)	Near-field or circuit board error	No transmission: transmitter unable to control the machine.	<ul style="list-style-type: none"> ■ Hardware fault. 	<ul style="list-style-type: none"> ■ Contact Wacker Neuson Product Support.
f n	Green (blinking rapidly) or Red (steady)	Joystick or function key error	Transmitter unable to control the machine.	<ul style="list-style-type: none"> ■ Operating error within a function key, or one or both joysticks. 	<ul style="list-style-type: none"> ■ Contact Wacker Neuson Product Support.

4.12 Light Ring Color Codes

Color—Code	Mode	Reason / Remedy
Amber—solid	Non communication	Machine's key in ON position, but: <ul style="list-style-type: none"> ■ Transmitter is not turned on. ■ Transmitter battery is dead. ■ Transmitter not pointed at machine. ■ Transmitter too far from machine. ■ Transmitter and decoder are on different channels. ■ Communication fault (see topic <i>Communication Faults</i>)
Amber—slow flash	Normal operation	Machine is receiving proper signal from transmitter and is operational.
Amber—fast flash	Operator safety	Machine is receiving signal but operator is too close to machine. <ul style="list-style-type: none"> ■ Move farther than two meters (6 feet) from machine until amber lights flash slowly.
Red—solid	Machine shut down	Critical error has occurred such as: tip over, low oil pressure, or high coolant temperature. <ul style="list-style-type: none"> ■ For tip over: Turn key OFF, upright machine. See topic <i>Resetting the ECM Diagnostic Data and the Tip-Over Light</i>. ■ For low oil pressure: Turn key OFF. Check oil. Restart as normal. ■ For high coolant temperature: Turn key OFF. Allow machine to cool. Add coolant.
Red—slow flash	Automatic glow plug	Glow plugs are preheating engine. No functions allowed until preheat cycle is complete.
Red—fast flash	Over voltage	Machine is receiving more than 18 Volts due to non-12V system used for jump starting. <ul style="list-style-type: none"> ■ Replace machine's 12V battery. ■ Do not jump-start the machine.

4.13 Infra-red System and Control Channels

The infrared (IR) system consists of three main components: the SmartControl™ SC-3 transmitter **(a)**, the receiving eyes **(b)**, and the decoder module **(c)**.

The receiving eyes are positioned on the top of the machine enclosed within protective lenses. They receive, filter and amplify the infrared transmission. They include:

- An integrated pre-amp to strengthen signal input
- IR correction, to filter outside light interference
- A frequency range of 500 kHz

There is an amber LED **(d)** on the base (bottom) of the front and rear receiving eyes. When illuminated, the amber LED indicates:

- Electric power is being supplied to the eye. The LED illuminates for the first 1–2 seconds after power has been applied (key switch is turned on).
- The eye is receiving a signal from the SmartControl™ SC-3 transmitter module. The LED will remain on during operation.

The decoder module is positioned behind the hydraulic manifold at the back of the machine. It receives, decodes, and outputs the signal from the transmitter module. It is also the electric power supply for all hydraulic solenoids.

The IR system can be set to one of sixteen different control channels. Using different channels allows multiple rollers to operate in the same area without interference. Whenever multiple rollers are operated within 20 meters (65 feet) of one another, make certain each roller and its accompanying transmitter is set to a different control channel than the other rollers/transmitters being used within the area.

Channel selection rotary switches **(e and f)** are included on both the transmitter module and on the decoder module. The switches come from the factory set to the last digit of the machine's serial number. For proper operation, BOTH switches must be set to the SAME channel. The channel of each transmitter/machine pair is identified by a label on both on the transmitter and the machine.

To change the control channel:

1. Remove the transmitter module battery and rotate the selector switch to the desired position. Re-install the transmitter module battery.
2. Set the rotary switch on the decoder module to the same position as that of the rotary switch on the transmitter module.
3. To determine if the decoder module and the transmitter module are set to the same channel, turn the key switch to the ON position and set the transmitter module's ON/OFF switch to the ON position. The amber lights on the machine's light ring should blink at a slow rate indicating that the machine is receiving signals from the transmitter module. If the amber lights illuminate but do not blink, the transmitter module and the decoder module are not set to the same channel.
4. Change the channel identification label to match the selected channel each time the channel is changed. Channel identification labels are supplied with the Operator's Manual.

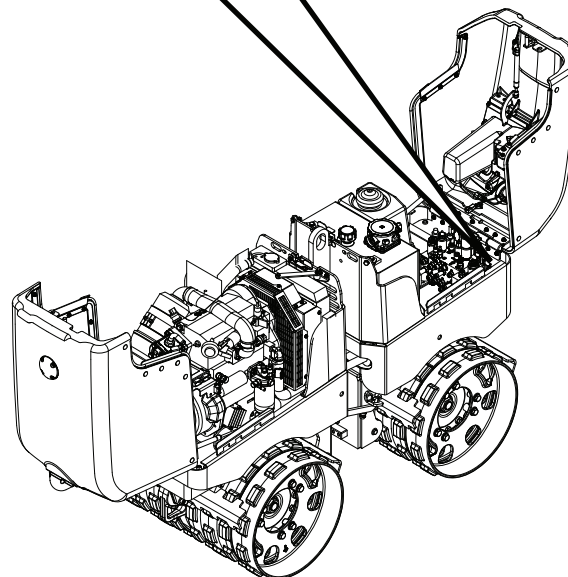
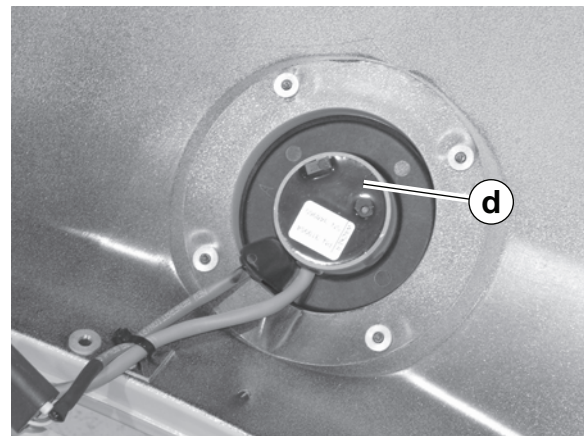
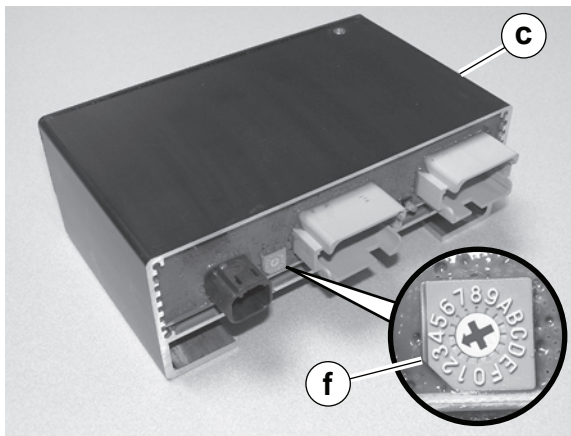
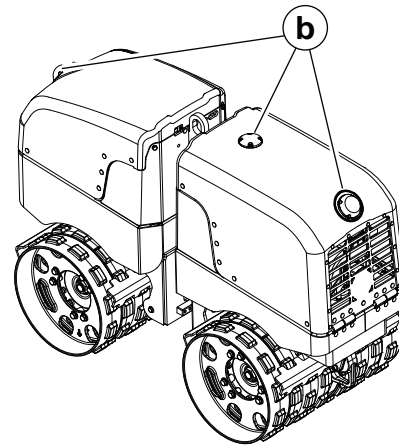
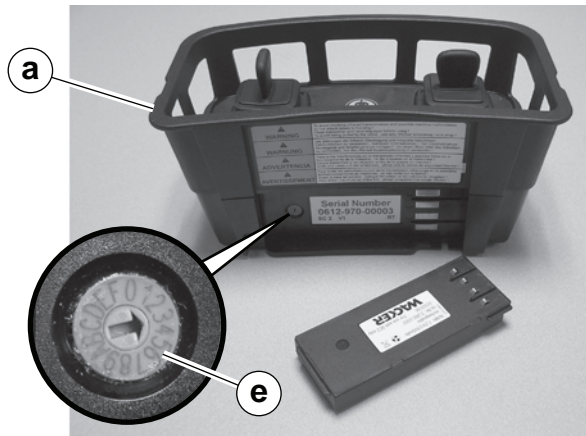

wc_gr012189

4.14 Position of the Operator

Although the receiving eyes on the machine can receive signals from any direction, the switches on the transmitter are positioned so that they correspond to the movements of the machine with the operator standing BEHIND it.

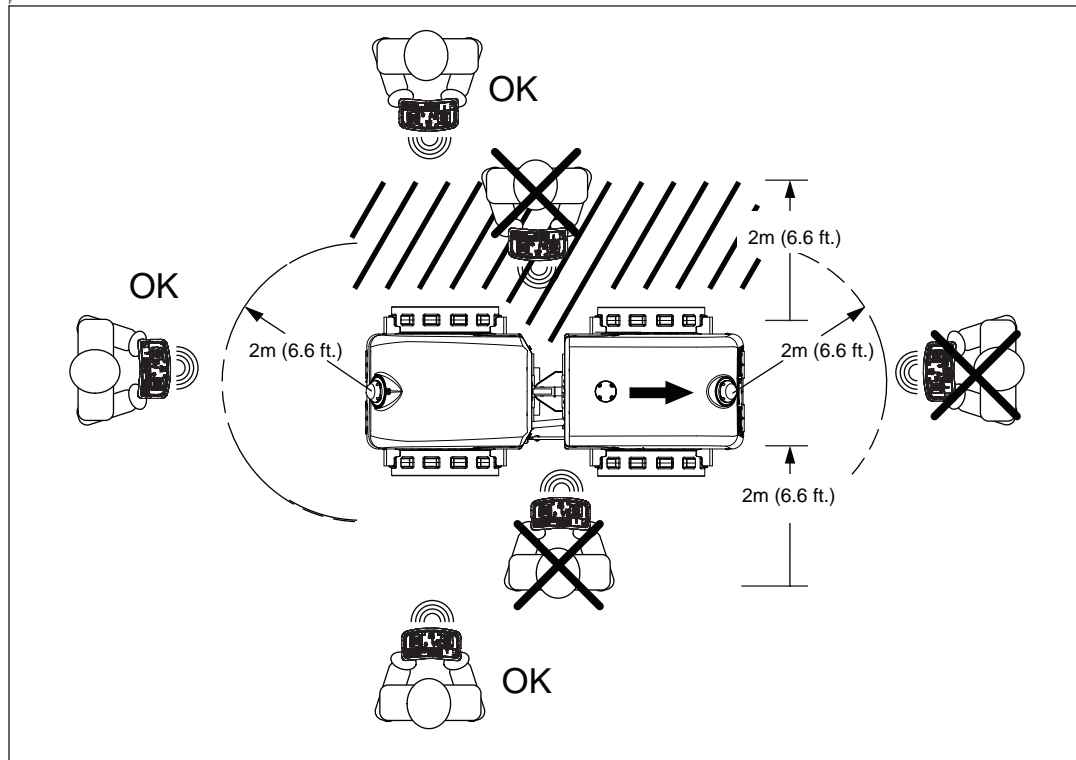

wc_gr012177

4.15 Range Limits

The transmitter signal will remain in contact with the machine at distances up to 20 m (65 ft). If operating into direct sunlight or with a low battery charge, the operating range may decrease.

If the machine moves out of range, the amber lights on the machine will stop blinking and come on continuously. The machine will immediately stop moving, and vibration will stop. The operator must then move closer to the machine to re-establish contact. If contact is not made within 30 seconds, the engine will shut off.

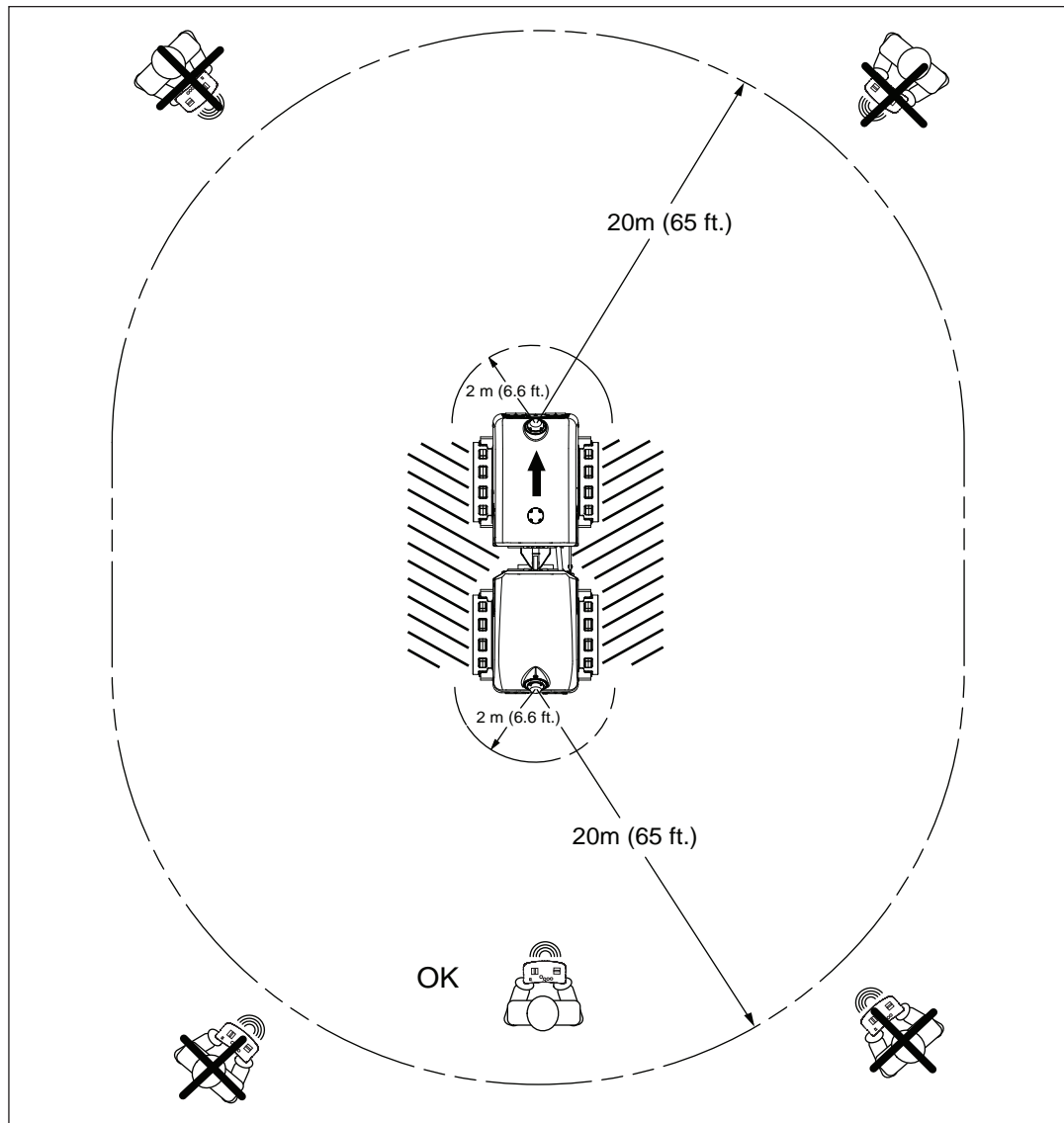

wc_gr012186

4.16 Operating Characteristics



WARNING

Personal injury or equipment damage hazards. The roller's sensing system will not stop the roller from moving when the transmitter is in the storage compartment or on the side of the roller.

- ▶ When operating from the side of the machine, always maintain a distance of at least 2m (6.6 ft.) from the machine.
- ▶ Never operate the machine with the transmitter in the storage compartment.

- In some instances, objects passing between the machine and transmitter (such as support beams) will block the signal. When this occurs, the machine will stop moving. If the signal is not re-established within 30 seconds, the engine will shut down.
- In an enclosed area (such as a shop floor or warehouse) or an area surrounded by large structures, the infra-red signal may reflect off surrounding surfaces, causing it to be picked up by the machine even when the transmitter is pointed away from the machine. This condition is more pronounced at shorter distances when the signal strength is strong.
- As the distance between the transmitter and machine increases, the intensity of the signal diminishes.

4.17 Communication Faults

Description The decoder has built-in diagnostics that continuously check for a faulty signal transmitted from the receiving eyes to the decoder. If a faulty signal is detected, the decoder stops machine movement and the light rings illuminate solid amber.

Fault correction Communication faults may occur when a receiving eye is damaged. The faults vary in frequency and duration. When a normal signal is restored, the light rings slowly flash amber and machine movement is restored.

If communication faults occur regularly, check the condition of the receiving eyes. Replace damaged components as needed.

4.18 Machine Stability



WARNING

Crushing hazards. Certain job site conditions or operating practices may adversely affect machine stability.

- ▶ Follow the instructions below to reduce the risk of tipping or falling incidents.

Surface conditions

Pay attention to changing surface conditions while operating the machine. Adjust speed and travel direction as necessary to maintain safe operation.

- Machine stability and traction may be severely reduced when operating on uneven or rough terrain, rocky soils, or wet or loosely packed surface material.
- The machine may suddenly tip, sink, or fall when moved onto surfaces that have been newly filled with earth.

Steering angle

An articulated roller is more likely to tip when moving off an elevated surface if the machine is turned away from the edge.

- ▶ As shown in the illustration on the right, always turn the machine toward the edge when moving off an elevated surface.



wc_gr007076

Travel speed

A fast moving machine is more likely to tip or fall over while making turns or changing direction.

- ▶ Reduce travel speed before turning the machine.

Drum overhang

The machine can tip suddenly if more than half of the drum width extends beyond the edge of the elevated surface.

- ▶ Reduce travel speed and watch the drum position carefully when operating along the edge of an elevated surface.
- ▶ Keep as much of the drum on the elevated surface as possible.

Vibrating on a compacted surface

Activating the vibratory system on a fully compacted surface may cause the drums to rebound and momentarily lose contact with the ground. If this occurs while the machine is on an incline, the machine may slide.

- ▶ If the drums rebound on the compacted surface, reduce vibration speed or stop vibration entirely.

4.19 Operating on Slopes

Background When operating on slopes or hills, special care must be taken to reduce the risk of personal injury or damage to the machine.

Procedure Always operate the machine up and down slopes rather than from side to side. The machine is equipped with safety switches which will shut down the engine should the side-to-side operating angle exceed 45°. Forward/backward tilt is not limited by the safety switches. For safe operation and for protection of the engine, continuous duty use should be restricted to slopes of 14° (25% grade) or less.



WARNING

Crushing hazard. Never operate the machine sideways on slopes. The machine may tip or roll over even on stable ground.

► Operate the machine straight up and down slopes.

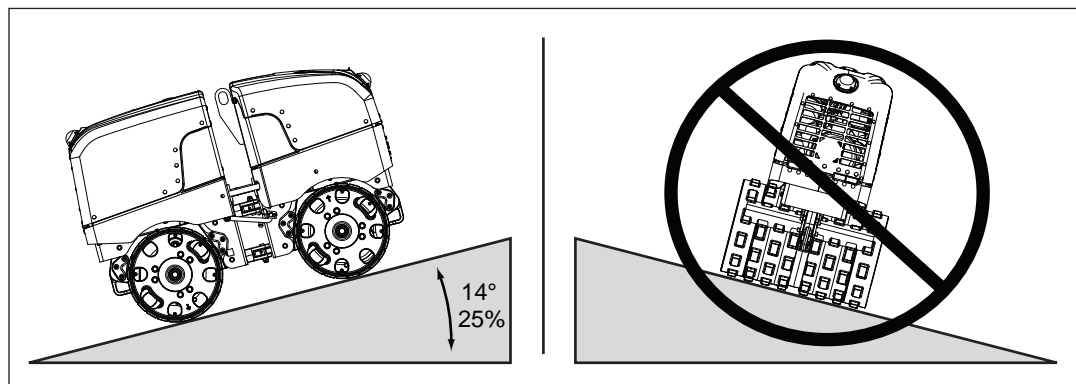

wc_gr012174

4.20 Rollovers

Proper operation of the machine on slopes will prevent rollovers. Read and follow safety instructions in the topic *Operating on Slopes*. If a machine rollover does occur, care must be taken to prevent damage to the engine. If the machine has rolled over, oil from the engine crankcase can flow into the combustion chamber, which can severely damage the engine the next time it is started. If the machine has rolled on its side, immediate steps should be taken to position the machine upright.

NOTICE: To prevent damage to the engine after a rollover, the machine must NOT be started, AND must be serviced to remove any oil that may have been trapped in the combustion chambers. Contact your local Wacker Neuson dealer for instructions or servicing.

A rollover is indicated by the tip-over light which flashes when in the “FLASH LED” mode or stays on solid when in the “LOCK OUT START” mode. See section *Programming the ECM Tip-Over Mode*.

4.21 Refueling the Machine

- Requirements**
- Machine shut down
 - Machine/fuel tank level with the ground
 - Fresh, clean fuel supply
-

Procedure Perform the procedure below to refuel the machine.



WARNING

Fire hazard. Fuel and its vapors are extremely flammable. Burning fuel can cause severe burns.

- ▶ Keep all sources of ignition away from the machine while refueling.
 - ▶ Do not refuel if the machine is positioned in a truck fitted with a plastic bed liner. Static electricity can ignite the fuel or fuel vapors.
 - ▶ Refuel only when the machine is outdoors.
 - ▶ Clean up spilled fuel immediately.
-

1. Remove the fuel cap.
 2. Fill the fuel tank up to the base of the neck.
-



CAUTION

Fire and health hazard. Fuel expands when heated. Expanding fuel in an over-filled tank can lead to spills and leaks.

- ▶ Do not overfill the fuel tank.
-

3. Re-install the fuel cap.
-

Result The machine has now been refueled.

4.22 Before Starting

Before starting the machine, check the following items:

- Read safety instructions at the beginning of this manual
- Check fuel level
- Check engine oil level
- Check hydraulic fluid level
- Check fuel lines
- Check air cleaner
- Check water level
- Make sure scraper bars are clean and properly adjusted
- Clean the transmitter and receiving eyes
- Check that the articulated joint locking bar is in the storage position
- Check that the SmartControl™ transmitter module and the machine's decoder module are set to the same control channel

Note: *All fluid levels should be checked with the machine on a level surface.*

4.23 Starting, Operating, and Stopping the Machine

- Requirements**
- Machine is in serviceable condition and has been properly maintained
 - There is fuel in the tank

Starting the machine

Perform the procedure below to start the machine.

1. Set the throttle switch **(a)** to the low speed (idle) position.

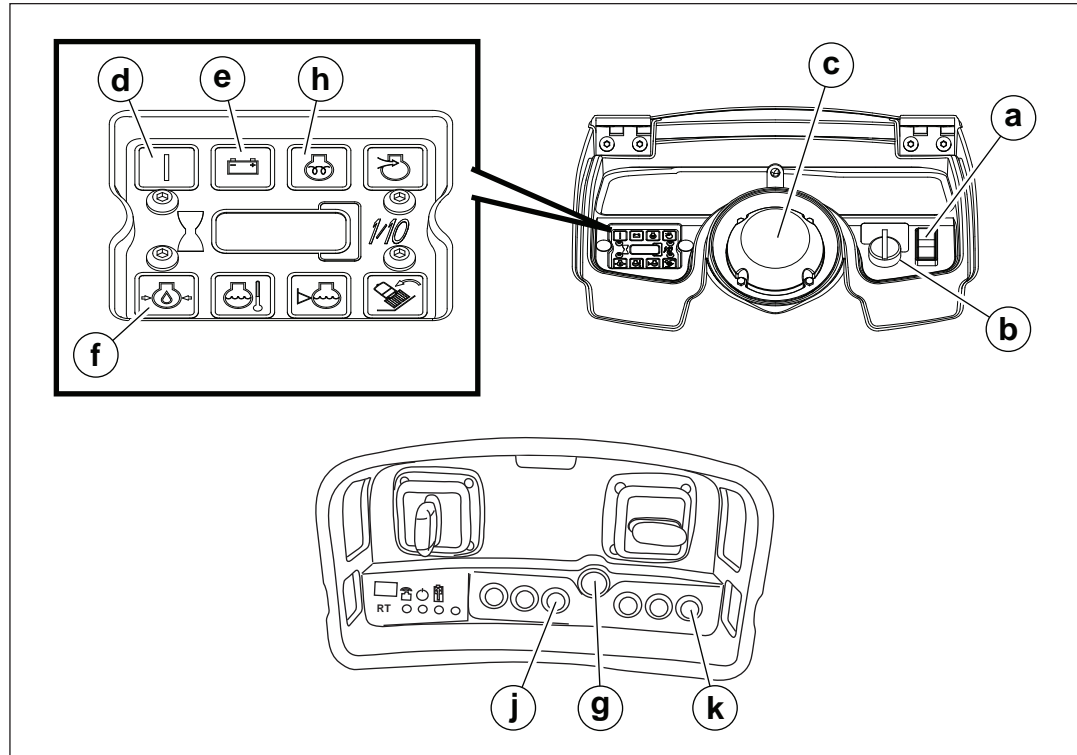

wc_gr012210

2. Rotate the starting key **(b)** clockwise to the ON (I) position.
 - All lights on the display/control panel and the light ring **(c)** (both red and amber) will illuminate for a 5-second LED test.
 - After 5 seconds, all lights go off except the power ON indicator **(d)**, charge indicator **(e)**, engine oil pressure indicator **(f)**, and the amber LEDs of the light ring which remain illuminated.

This procedure continues on the next page.

Continued from the previous page.

3. Turn on the SmartControl™ SC-3 transmitter by pressing the red ON/OFF pushbutton **(g)**. Make sure the amber indicator lights in the light rings **(c)** are flashing at a slow rate. This indicates infrared reception and that the transmitter is at the correct distance from the machine. If they are not flashing, it indicates that either the transmitter is not on or that the control channel of the transmitter does not match the control channel of the machine. If they are flashing at a fast rate (three times per second), it indicates that the transmitter (and operator) are too close to the machine. Reposition the SmartControl™ SC-3 transmitter so that the indicator lights flash at a slow and steady rate. If you are operating multiple rollers, check to make certain each roller and its accompanying transmitter are set to a different control channel.
4. After approximately 2 seconds, if engine conditions dictate (coolant temperature too cool), the glow plug indicator **(h)** will illuminate and the light ring will flash red, signifying that the glow plugs are on. The colder the engine coolant temperature, the longer the glow plugs will stay on:
 - approximately 30 seconds at 0°C (32°F) for Kohler powered machines.
 - approximately 5 seconds at 0°C (32°F) for Kubota powered machines.

Note: *The starter will not crank during the glow plug cycle.*

5. Immediately after the glow plug light **(h)** and red light ring **(c)** go out, press the engine start pushbutton **(j)** and hold it down until the engine starts. If the machine fails to start within 15 seconds of cranking, release the engine start pushbutton. Press the red ON/OFF pushbutton to turn the transmitter off. Wait 30 seconds, then turn the transmitter back on and repeat the starting procedure.
6. Once started and sufficient oil pressure is sensed, the oil pressure indicator will go out.
7. Allow the unit to warm up a minimum of 5 minutes before engaging the throttle switch **(a)** to the *high* (fast) position.



WARNING

Personal injury or equipment damage hazards. The roller's sensing system will not stop the roller from moving when the transmitter is in the storage compartment or on the side of the roller.

- ▶ When operating from the side of the machine, always maintain a distance of at least 2m (6.6 ft.) from the machine.
- ▶ Never operate the machine with the transmitter in the storage compartment.



WARNING

Personal injury hazard.

- ▶ Stop the machine if people enter in the work area of the machine.

This procedure continues on the next page.

Continued from the previous page.

Operating the machine

Follow the guidelines below to use your Trench Roller to its fullest capacity.

- When standing behind the machine (**k**), pushing forward on the forward/reverse joystick causes the machine to move away from the operator, pushing left on the steering joystick results in the machine turning left, etc.

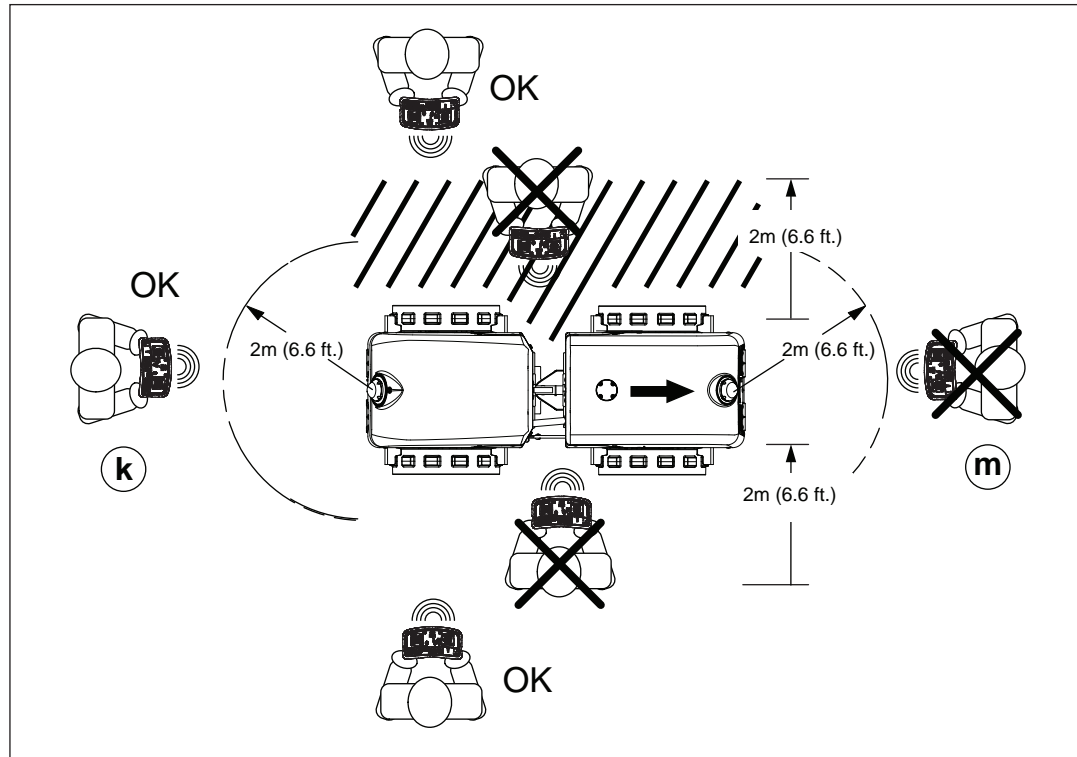

wc_gr012211

- As the operator changes positions in the work area, it is important that he or she understands the changes that will occur in the control of the machine. If the operator stands in front of the machine (**m**), it will respond in a direction opposite in relation to the operator. That is, pushing forward causes the machine to move toward the operator; pushing left results in the machine turning to the operator's right. Operating the machine while standing in front of it is not recommended.
- Operate the machine with the transmitter pointed at the receiving eyes on the machine for continued operation. The light ring amber LEDs will blink to show that the machine is receiving signals from the transmitter.
- The infrared system is equipped with an operator distance sensing system. If the operator is standing within 1–2 m (3–6 ft.) of the front or rear of the machine, the amber light ring will flash rapidly, and the machine will not travel forward/reverse or vibrate until the operator moves outside the 1–2 m (3–6 ft.) distance. Once the operator is at the correct distance, the amber lights will flash slowly to indicate the machine can be operated.

Note: *The control cable is not needed for using the infrared system.*

This procedure continues on the next page.

Continued from the previous page.

- Multiple rollers are not to be operated within 20 meters (65 feet) of one another, unless you are certain you have each roller and its accompanying transmitter set to a different control channel than the other rollers/transmitters being used within the area. Refer to section *Infra-red System and Control Channels* for additional information. Failure to assign different control channels can, in certain circumstances, cause one transmitter to inadvertently take control of more than one machine.
- Always use the SmartControl™ SC-3 transmitter neck strap provided by Wacker Neuson while operating with the control cable connected. This neck strap is designed to break away so that the operator will not be dragged by the machine should the machine slide, tip, or fall.

Stopping the machine

Perform the procedure below to stop the machine.

1. Turn the vibration off by pressing the vibration off pushbutton **(k)**.
2. Place the throttle switch **(a)** in the low speed (idle) position.

Note: *The engine cannot be shut down using the throttle switch alone. The throttle switch only changes the engine speed from high speed (fast) to low speed (idle).*

3. Turn off the SmartControl™ SC-3 transmitter by pressing the red ON/OFF pushbutton **(g)**. The machine's engine will shut down.
4. Rotate the starting key **(b)** counterclockwise to the OFF (O) position.

Note: *The machine has a built-in shutoff timer. If the starting key is left in the ON position when the engine is not running, the timer will shut off the power to the control panel after one hour.*

A parking brake is located in the rear drum. The brake is connected to the hydraulic system through the brake valve of the control manifold. The brake is spring activated and hydraulically disengaged. Hydraulic oil flow to the brake is enabled as soon as the engine starts. Thus, when the engine is running, the brake is disengaged; when the engine is not running, the brake is engaged.

4.24 Emergency Shutdown Procedure

If a breakdown/accident occurs while the machine is operating, follow the procedure below.

1. Turn off the transmitter to stop the engine and close the fuel valve.
2. Turn the roller keyswitch to the OFF position.
3. Return the machine to an upright position if tipped over.
4. Contact rental yard or machine owner.

4.25 NiMH Battery

The battery used to power the transmitter is a high capacity Nickel Metal Hydride (NiMH) cell rated at 2000 mAh and is capable of accepting hundreds of charging cycles. If the machine fails to operate for the full operating period, even after the battery has been fully discharged and recharged, the battery pack may need to be replaced.

Charging characteristics:

- Time to fully charge: 2 hours
- Full-charge operating time: 16 hours*
- Operating time after 1 hour charge: 8 hours*
- At temperatures below 0°C, charging is not possible

* Operating time decreases at severely cold temperatures.

4.26 Replacing the Battery Pack

The battery pack **(a)** on the back of the transmitter should be replaced once a year or when it no longer holds a full charge.

To replace the battery pack press the orange tab **(b)** and slide the battery pack out.

Notes

- A new battery may not be fully charged. After replacing the battery, charge it for approximately one hour to ensure it is at full capacity.
- In the interests of environmental protection, dispose of used batteries properly. Do not dispose in trash, or incinerate.

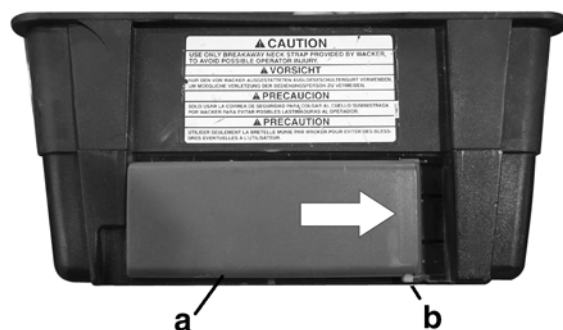

wc_gr001666

4.27 Charging the Transmitter Battery

Background The NiMH battery pack **(b)** in the transmitter has enough capacity to provide 16 hours of continuous operation. To maintain battery capacity, recharge it during non-working hours by using the onboard docking port.

Note: *There is no need to run the NiMH battery completely down before recharging. The battery can be recharged from any state of discharge with no loss in performance or life.*

Procedure To charge the battery, perform one of the following procedures:

- Plug the transmitter receptacle **(a)** into the charging port **(b)**. Slide the transmitter forward until the battery charge light comes on.

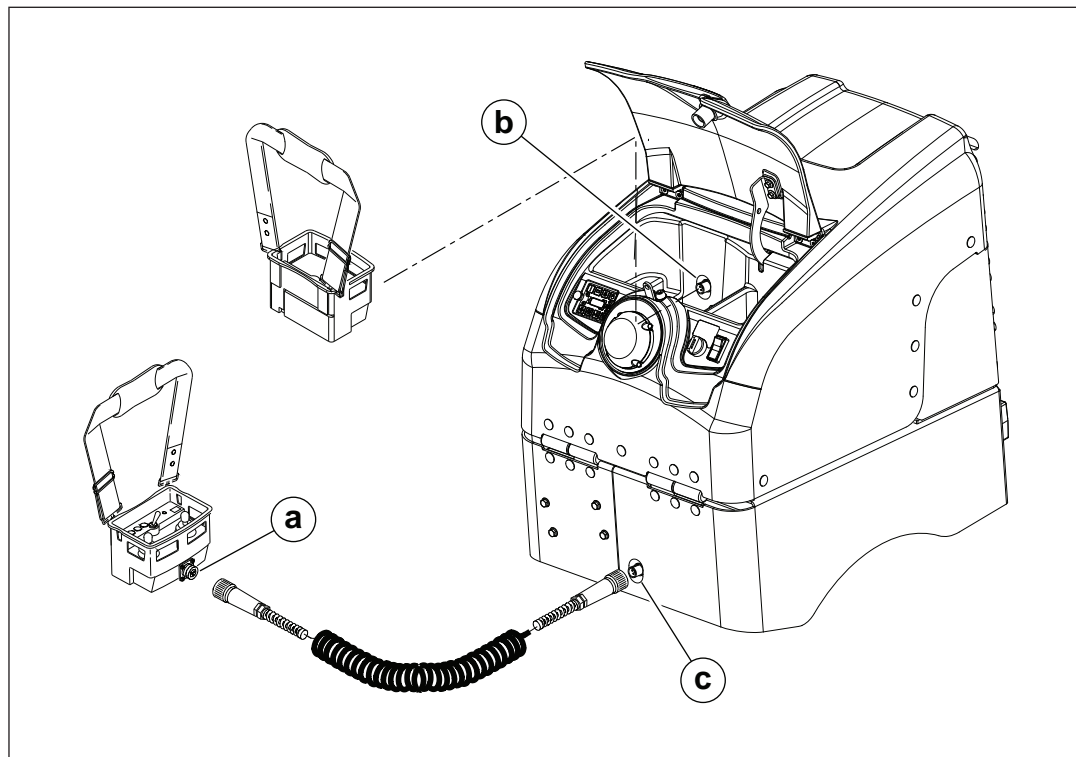

wc_gr012187

- Plug one end of the control cable into the transmitter receptacle **(a)** and the other end into the port **(c)** on the back of the machine.

Note

- Using the second method requires the machine to be running or the keyswitch to be in the "ON" position.
- The Cable Control System will only charge the transmitter battery if the control cable is connected to the transmitter receptacle **(b)** and plugged into the port **(a)** in the back of the roller.

Charging time Approximately 2 hours is required to bring the transmitter battery up to full charge. This is the most efficient way to use the battery. The transmitter will operate with a partially charged battery; however, its operating time will be reduced accordingly.

Note: *The charging circuit in the transmitter is self-regulating and limits the charging current to the battery, so that the battery cannot be overcharged.*

Notes

5 Engine Control Module (ECM) Diagnostics

5.1 Overview of the ECM and the Diagnostic Tool

The RT-SC3 Roller features an Engine Control Module (ECM) with diagnostic and programmable abilities. The diagnostics are conveyed via alpha-numeric codes displayed on three LED displays that are viewable through the plastic case of the ECM. These diagnostic/program abilities include:

- The ability to view the stages of engine start-up.
- The ability to view seven fault conditions and over 35 error codes.
- The ability to lockout or allow engine start after a machine tip-over.

A diagnostic tool, which comes standard with the machine, is used to interface with the ECM.

5.2 ECM Stages of Engine Start Up

The ECM displays codes as the machine goes through the start up sequence. These codes are described below.

Note: *It is not necessary to enter the diagnostic mode to view these codes.*

Code	State	Description
<ul style="list-style-type: none"> ■ 8.8.8 for 3 seconds ■ C 1.x for 2 seconds (Kohler) ■ H 1.x for 2 seconds (Kubota) ■ F_L or F_O for 3 seconds 	Power up	Power up delay cycle. Software version. Software version. Current tip over/roll over mode.
1	Stop/Idle	During this state, power is applied to the ECM and decoder but the engine is off. The ECM is waiting for the start signal to initiate the glow plug cycle.
2	Preglow	During this state, the glow sensor determines the glow time and power is applied to the glow plugs. This cycle starts immediately after the control box power switch is placed in the ON position.
3	Prestart	Post preglow state. The ECM is waiting for the starting cycle.
4	Start	Power is being applied to starter.
5	Post glow	5 second post glow after engine start.
6	Run	Standard running mode.
7	Fault	All functions stopped. Waiting repeat of power up cycle. Faults that produce engine shut down: <ul style="list-style-type: none"> ■ low oil pressure ■ over temperature ■ tip over ■ over voltage

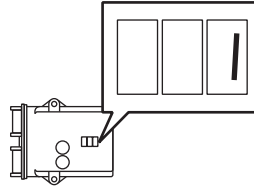

5.3 ECM Monitoring of Solenoids—Kohler Engine Only

The ECM monitors the wiring to, and condition of, the fuel solenoid and the wiring to, and condition of, the starter solenoid.

If the wire **(a)** to the fuel solenoid is disconnected or the fuel solenoid is faulty, the following results occur.

- The control panel indicators **(b)** will flash immediately after the transmitter is turned on.
- The red LEDs of the light ring will illuminate solid red.
- The engine will not crank.

Reconnect the wire or replace the fuel solenoid to enable the machine to start.

If the wire **(c)** to the starter solenoid is disconnected or the starter solenoid is faulty, the following results occur.

- The control panel indicators will flash immediately after the starter pushbutton is pressed.
- The red LEDs of the light ring will illuminate solid red.
- The engine will not crank.

Reconnect the wire or replace the starter solenoid to enable the machine to start.

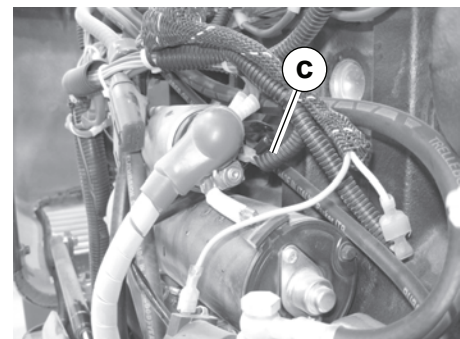
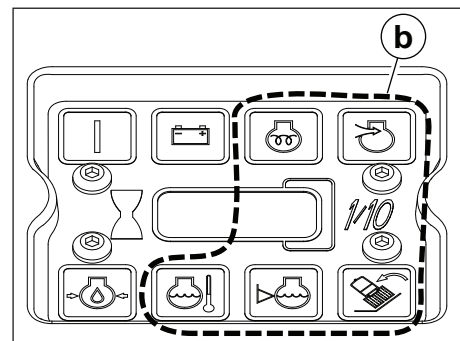
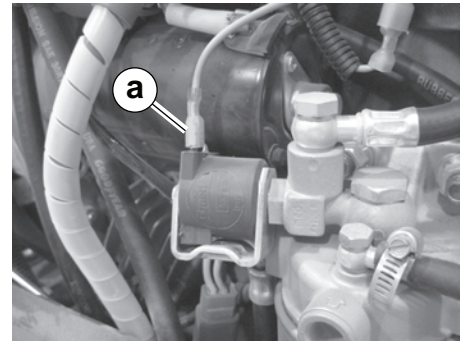

wc_gr012200

5.4 ECM Monitoring of Solenoids—Kubota Engine Only

The ECM monitors the wiring to, and condition of, the stop solenoid and the wiring to, and condition of, the starter solenoid.

If the connector harness **(a)** to the stop solenoid is disconnected or the stop solenoid is faulty, the following results occur.

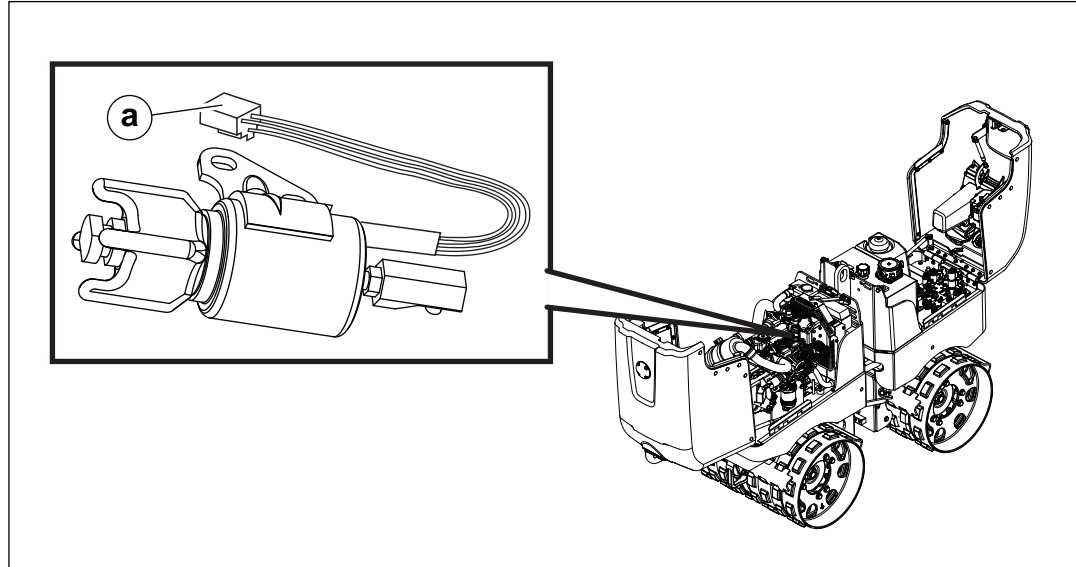

wc_gr012437

- The control panel indicators **(b)** will flash immediately after the transmitter is turned on.

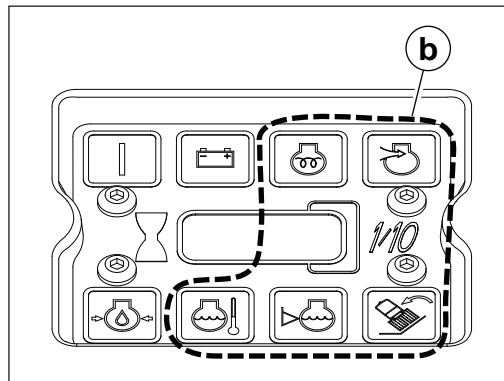

wc_gr012438

- The red LEDs of the light ring will illuminate solid red.
- The engine will not crank.

Reconnect the connector harness, check the wiring, or replace the stop solenoid to enable the machine to start.

This procedure continues on the next page.

Continued from the previous page.

If the wire **(c)** to the starter solenoid is disconnected or the starter solenoid is faulty, the following results occur.

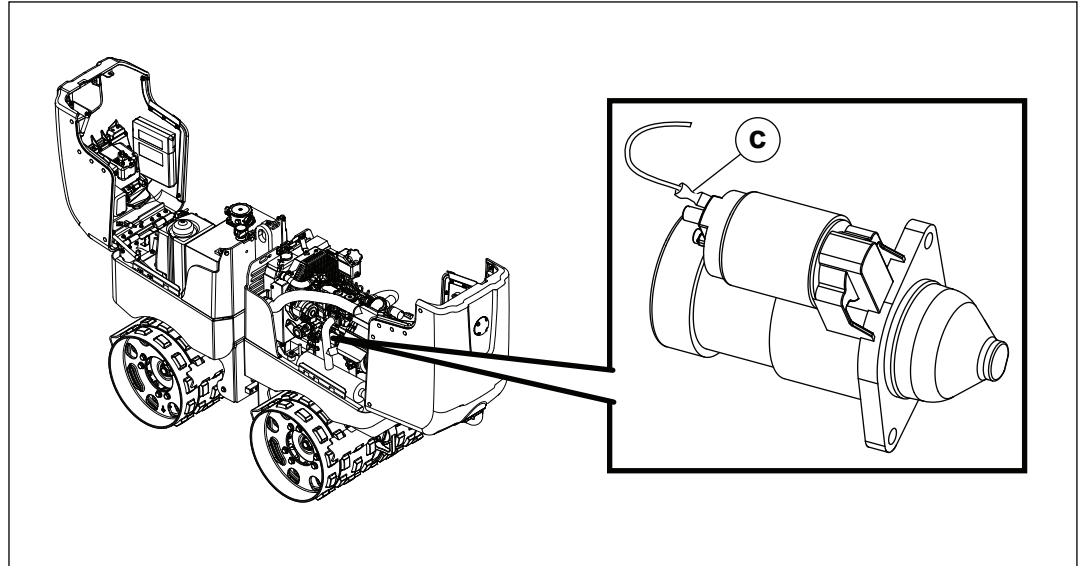

wc_gr012439

- The control panel indicators will flash immediately after the starter pushbutton is pressed.
- The red LEDs of the light ring will illuminate solid red.
- The engine will not crank.

Reconnect the wire or replace the starter solenoid to enable the machine to start.

5.5 Connecting the Diagnostic Tool—Kohler Engine Only

Use the diagnostic tool to access the diagnostic capabilities of the Engine Control Module (ECM).

To connect the diagnostic tool:

1. Shut down the machine.
2. Open the engine compartment.
3. Remove the cap from the connector **(a)** on the wiring harness.
4. Plug the diagnostic tool **(b)** into the wiring harness.

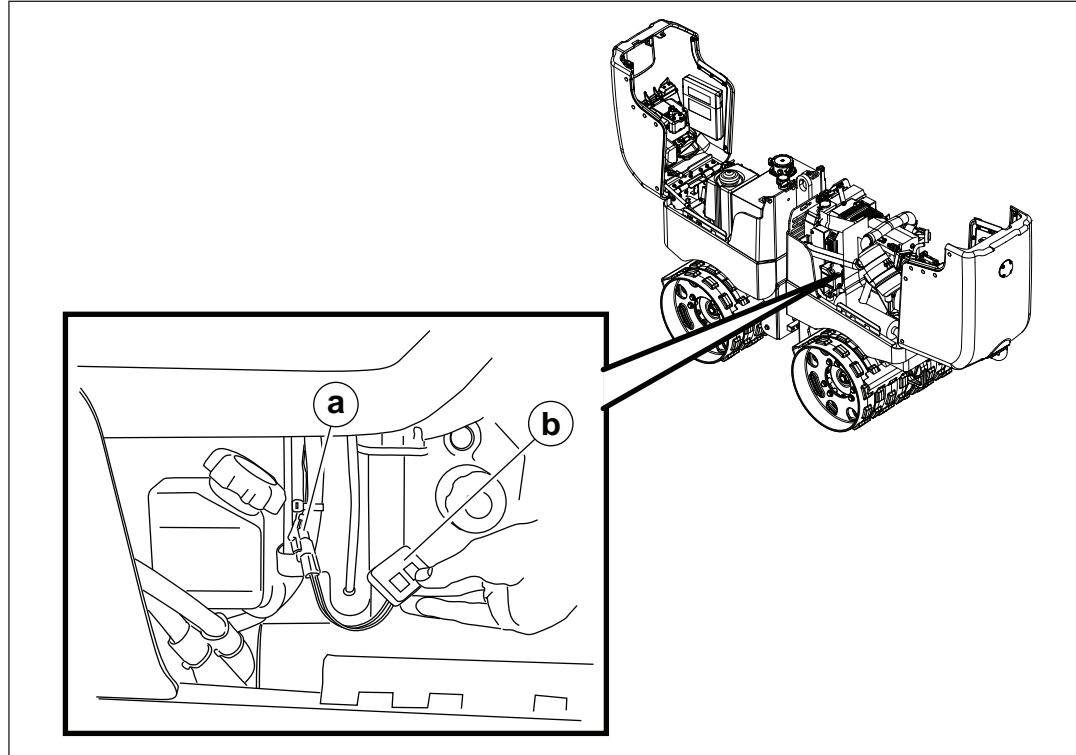

wc_gr012201

5.6 Connecting the Diagnostic Tool—Kubota Engine Only

Use the diagnostic tool to access the diagnostic capabilities of the Engine Control Module (ECM).

To connect the diagnostic tool:

1. Shut down the machine.
2. Open the engine compartment.
3. Remove the cap from the connector **(a)** on the wiring harness.
4. Plug the diagnostic tool **(b)** into the wiring harness.

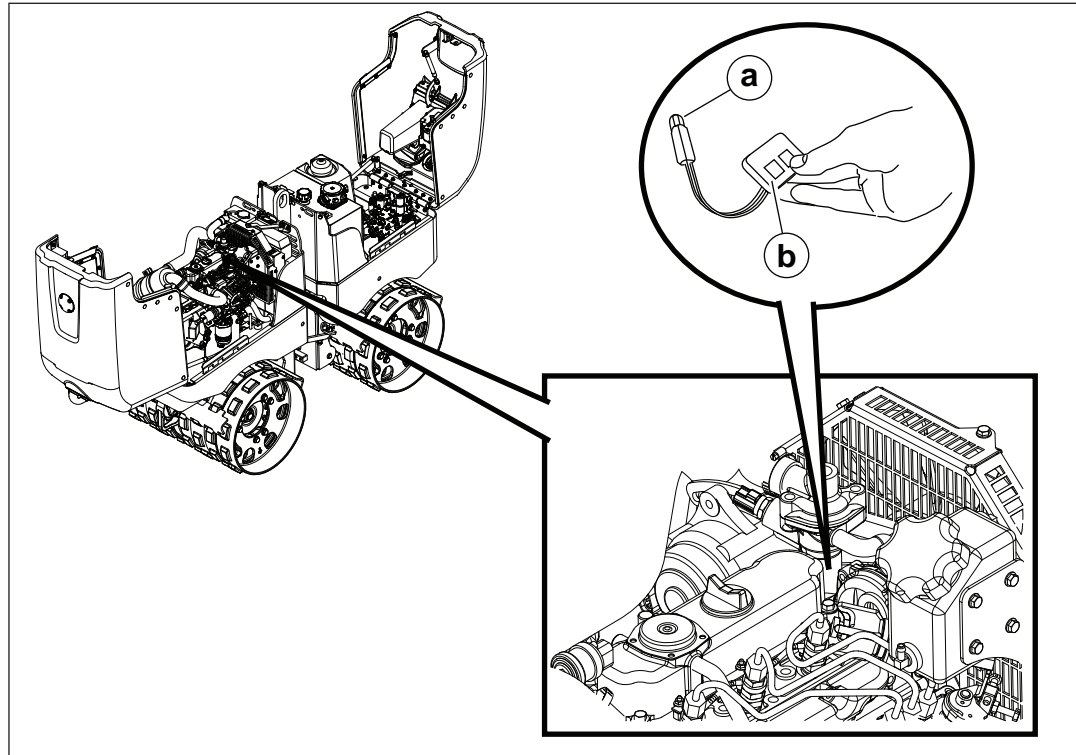

wc_gr012423

5.7 Programming the ECM Tip-Over Mode

To set the ECM tip-over mode:

1. Connect the diagnostic tool. See section *Connecting the Diagnostic Tool*.

2. Do one of the following:

- Press and hold button “A” of the diagnostic tool and turn the key to ON. This will set the ECM to the FLASH LED mode.

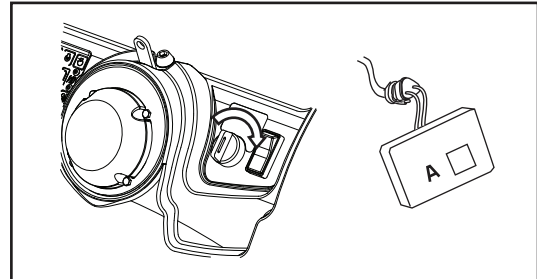

wc_gr012202

or

- Press and hold both of the buttons of the diagnostic tool and turn the key ON. This will set the ECM to the LOCK OUT START mode.

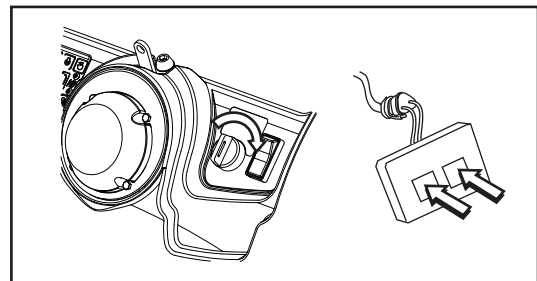

wc_gr012203

3. Check the mode setting by observing the LED display of the ECM during the 5 seconds immediately after turning the key ON.

“L_O” = LOCK OUT START

“F_L” = FLASH LED

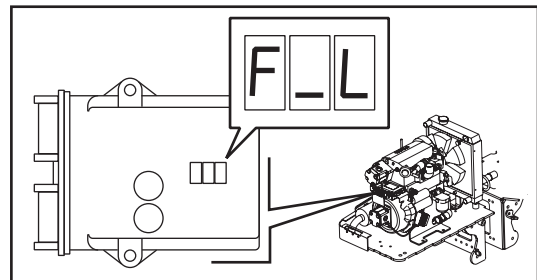

wc_gr005050

5.8 Entering the ECM Diagnostic Mode

Perform the procedure below to enter the ECM diagnostic mode.

1. Begin with the key **(a)** in the OFF position.

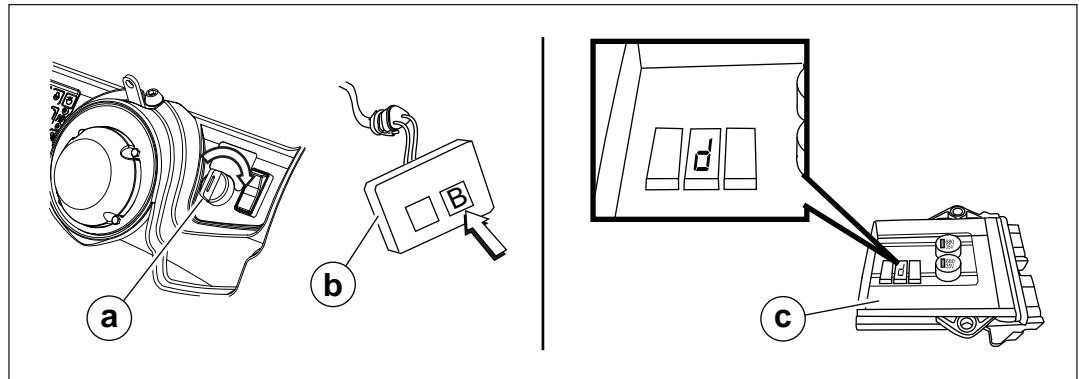

wc_gr012204

2. Connect the diagnostic tool **(b)**. See topic *Connecting the Diagnostic Tool*.
3. Press and hold button "B" of the diagnostic tool. While holding button "B," turn the key to the ON position. Release button "B" when the letter "d" appears on the ECM **(c)**. The ECM diagnostic mode is now active.
4. Refer to the following topics for specific diagnostic procedures:
 - *ECM Fault and Error Codes*
 - *Resetting the ECM Diagnostic Data and the Tip-Over Light*

To exit the ECM diagnostic mode, turn the key to the OFF position.

5.9 ECM Fault and Error Codes

Background Machine fault and error codes are viewable on the three LED displays of the ECM. The tip over fault is always viewable after engine start. To view all other fault and error codes, the diagnostic mode of the ECM must be entered and the diagnostic tool must be connected.

Fault codes Each fault code consists of two sets of digits. The first set includes the letter “F” and represents the type of fault. The second set represents the number of times the fault has occurred or the time elapsed since the ECM has been cleared. **Note:** *All fault codes are displayed, even if there has not been a fault.* The fault codes scroll across the three LED displays automatically.

Fault code examples:

- “F00-02” — the roller has tipped over two times since the codes were cleared.
- “F06-0024” — the starter has been engaged 24 times since the codes were cleared
- “F07-120.0 H” — the roller has accumulated 120 hours since the codes were cleared.

Error codes Each error code consists of one set of digits. Each includes the letter “E” and represents the type of error. **Note:** *Only codes for those errors that have occurred are displayed.* The error codes are displayed as fixed characters—they do not scroll across the LED displays automatically.

Error code example:

- “E07” — the oil pressure sensor is or has been unplugged.

Viewing

Follow the procedure below to view the fault and error codes.

1. Connect the diagnostic tool. See section *Connecting the Diagnostic Tool*.
2. Enter the diagnostic mode of the ECM. See section *Entering the ECM Diagnostic Mode*.
3. Use the buttons on the diagnostic tool to cycle through the codes. Pressing the “A” button of the diagnostic tool advances through the codes. Pressing the “B” button cycles through the codes in the opposite order.
4. The fault codes (F00 to F07) are displayed first followed by the error codes (E00 to E39). Pressing the buttons of the diagnostic tool cycles through the error codes and back to the fault codes.

Code	Description
F00	Number of tip faults
F01	Number of over heat faults
F02	Number of low oil pressure faults
F03	Number of eeprom faults (ECM memory fault)
F04	Number of over voltage faults
F05	Run time under restricted air flow
F06	Number of starts
F07	Engine run time

Code	Description
E00	Possible bad glow time sensor
E01	Possible bad temperature sensor
E02	Possible bad air flow sensor
E03	Possible bad oil pressure sensor
E04	Possible bad tip sensor
E05	Temperature sensor was unplugged
E06	Air restriction sensor was unplugged
E07	Oil pressure sensor was unplugged
E08	Open starter solenoid
E09	Open fuel solenoid (Kohler powered machines only)
	Open stop solenoid (Kubota powered machines only)
E10	Open throttle hold solenoid
E11	Open throttle pull relay
E12	Open glow plug relay
E13	Open RX power relay
E14	Open LED ring output
E15	Low battery
E16	Starter solenoid
E17	Shorted fuel solenoid (Kohler powered machines only)
	Shorted stop solenoid (Kubota powered machines only)
E18	Shorted throttle hold solenoid
E19	Shorted throttle pull relay
E20	Shorted glow plug relay coil
E21	Shorted RX power relay coil
E22	Shorted LED ring output
E23	High oil pressure on power up
E24	Starter solenoid over current
E25	Fuel solenoid over current (Kohler powered machines only)
	Over-current stop solenoid (Kubota powered machines only)
E26	Throttle hold solenoid over current
E27	Throttle pull relay coil over current
E28	Glow plug relay coil over current
E29	RX power relay coil over current
E30	LED ring output over current
E31	Open
E32	High starter solenoid current
E33	High fuel solenoid current (Kohler powered machines only)
	High stop solenoid current (Kubota powered machines only)
E34	High throttle hold solenoid current
E35	High throttle pull relay coil current

Code	Description
E36	High glow plug relay coil current
E37	High RX power relay coil current
E38	High LED ring output current
E39	Open

5.10 Resetting the ECM Diagnostic Data and the Tip-Over Light

To reset the ECM diagnostic data, and turn off the tip-over light (a), carry out the following procedure.

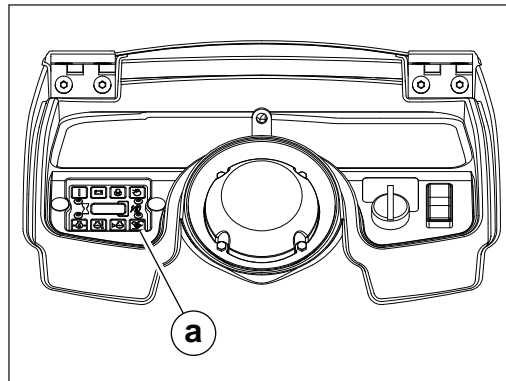

wc_gr012205

1. Connect the diagnostic tool. See section *Connecting the Diagnostic Tool*.
2. Enter the diagnostic mode of the ECM. See section *Entering the ECM Diagnostic Mode*.

Note: Before proceeding, it is important to realize all stored data will be erased.

3. While in the diagnostic mode, press and hold both buttons of the diagnostic tool for approximately 5 seconds and observe the ECM LED displays.

The ECM LED displays will change to nine dashes once the ECM has been reset.

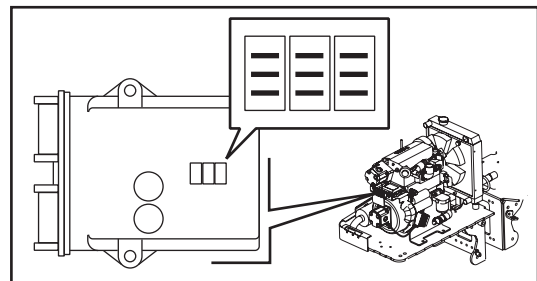
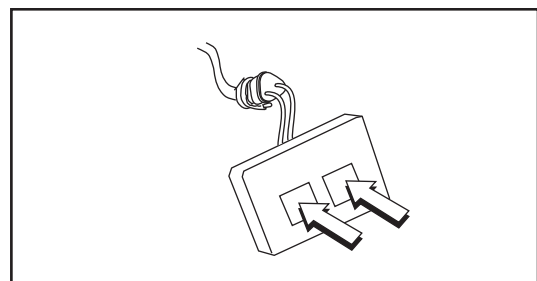

wc_gr005049

5.11 Calibrating the Joysticks

To determine if calibration is needed, press and release the red ON/OFF pushbutton **(j)**.

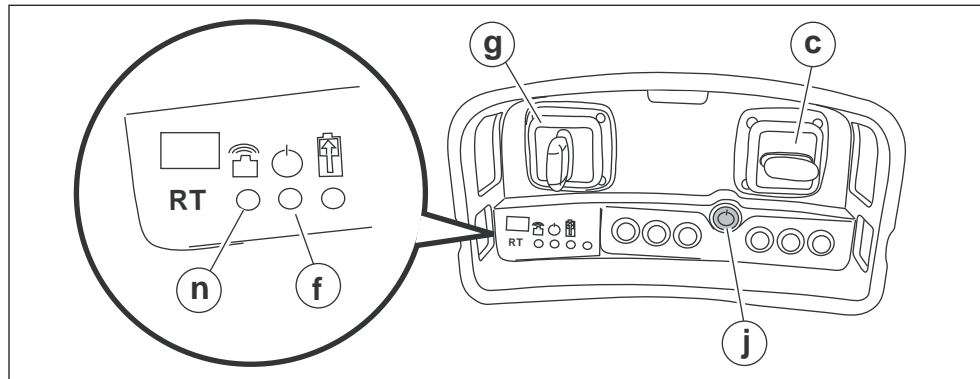

wc_gr010840

- If the joysticks are out of calibration, the signal transmission indicator **(n)** will illuminate red and remain lit, and the operating status indicator **(f)** will blink.
- If the joysticks are calibrated, the signal transmission indicator will remain dark, and the operating status indicator will blink.

Calibration procedure

All four joystick positions must be calibrated before the transmitter can return to its normal operating mode. Perform the procedure below to calibrate the joysticks.

1. Press and release the ON/OFF pushbutton to power up the transmitter.
2. Press and hold the ON/OFF pushbutton for approximately 3 seconds until the operating status indicator illuminates and remains lit. Release the ON/OFF pushbutton.
3. Press and hold the ON/OFF pushbutton again for approximately 3 seconds until the operating status indicator flashes rapidly. Release the ON/OFF pushbutton.
4. Move the forward/reverse joystick **(c)** all the way forward and hold it in place. While holding the joystick, press and release the ON/OFF pushbutton—the signal transmission indicator will flash. Release the forward/reverse joystick.
5. Move the forward/reverse joystick all the way backward and hold it in place. While holding the joystick, press and release the ON/OFF pushbutton—the signal transmission indicator will flash. Release the forward/reverse joystick.

This procedure continues on the next page.

Continued from the previous page.

6. Move the left/right joystick (**g**) all the way to the left and hold it in place. While holding the joystick, press and release the ON/OFF pushbutton—the signal transmission indicator will flash. Release the left/right joystick.
7. Move the left/right joystick all the way to the right and hold it in place. While holding the joystick, press and release the ON/OFF pushbutton—the signal transmission indicator will flash. Release the left/right joystick.

Result

The joysticks have now been calibrated.

Exiting calibration mode

The transmitter will automatically return to its normal operating mode after joystick calibration.

Note: *If you are unable to exit calibration mode, remove and re-install the transmitter battery. This will reset the system.*

6 Changing Drums (RTx-SC3)

6.1 Removing the Drum Extensions

Introduction RTx-SC3 machines are factory-equipped with four drum extensions; one attached to each drum. The overall width of the drums with extensions is 820 mm (32 in). By removing the drum extensions, the user can decrease the overall width of the drums to 560 mm (22 in.) as needed to accommodate specific job requirements.

- Requirements**
- Engine stopped; machine cool to the touch
 - Metric hand tools (sockets, wrenches, etc.)
 - Torque wrench
 - Narrow scrapers
 - Loctite 243 or equivalent

Procedure Perform the procedure below to remove the drum extensions.

1. Remove the three screws (**g**) and washers (**h**) and remove the wide scraper (**a**). Keep the screws (**g**) and washers (**h**) for installation of the narrow scraper described at the end of this procedure.

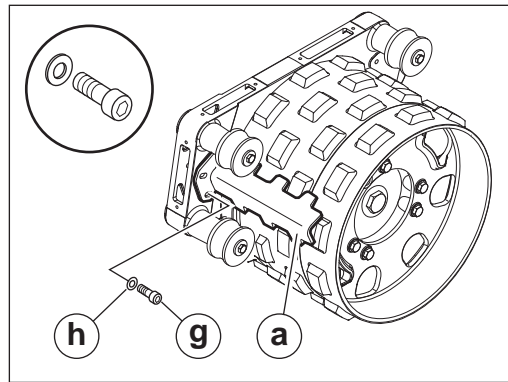

wc_gr010670

2. Remove the three M16 x 25 screws (**c**).

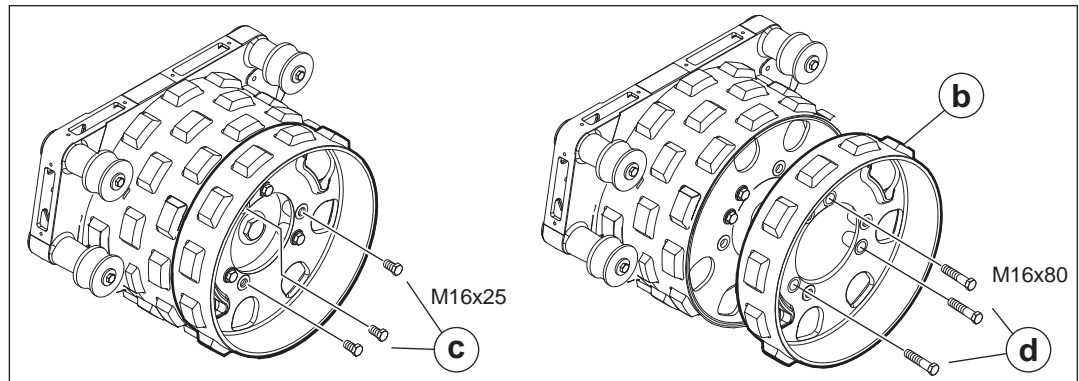

wc_gr010666

3. Remove the three M16 x 80 screws (**d**) and remove the drum extension (**b**).

This procedure continues on the next page.

Continued from the previous page.

4. Install the three M16 x 80 screws **(d)** into the threaded holes of the drum extension. (Use the holes where the M16 x 25 screws were installed.) Place the drum extensions, with screws installed, in storage for future use.

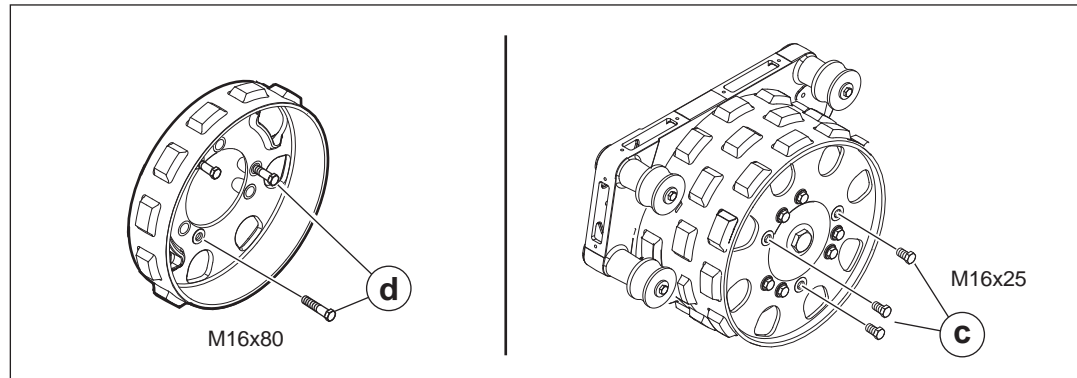

wc_gr010671

5. Install the M16 x 25 screws **(c)** to the drum in the locations shown. Use Loctite 243 or equivalent on the screws and torque them to 210 Nm (155 ft.lbs.).
6. Install the narrow scraper **(f)** using the screws **(g)** and washers **(h)** from step 1. Use Loctite 243 or equivalent on the screws and torque them to 86 Nm (63 ft.lbs.).

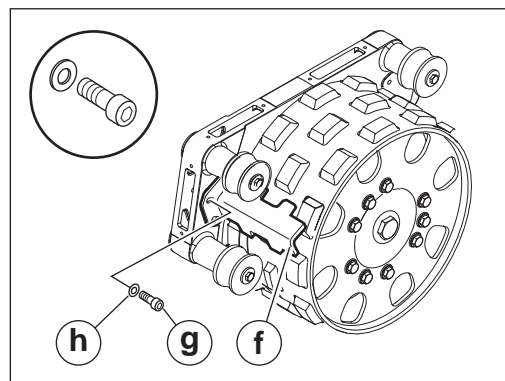

wc_gr010672

7. Repeat the procedure for each drum.

Result

The drum extensions have now been removed.

6.2 Installing Drum Extensions

Introduction The overall width of the drums on the RTx-SC3 is 560 mm (22 in.). By installing drum extensions, the user can increase the overall width of the drums to 820 mm (32 in.) as needed to accommodate specific job requirements.

- Requirements**
- Engine stopped; machine cool to the touch
 - Metric hand tools (sockets, wrenches, etc.)
 - Torque wrench
 - Drum extensions and mounting hardware
 - Wide scrapers and mounting hardware
-

Installing the drum extensions

Perform the procedure below to install the drum extensions.

1. Remove the narrow scraper (**f**) from the front drum. Place the scraper in storage for future use, but keep the screws (**g**) and washers (**h**) available. You will re-use the screws and washers to install the wide scraper at the end of this procedure.

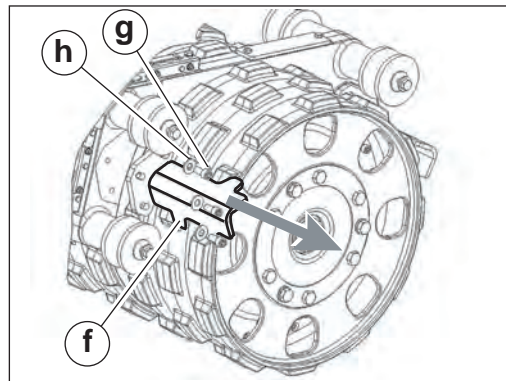

wc_gr009889

This procedure continues on the next page.

Continued from the previous page.

- Remove (3) M16 x 25 screws (c) from each end of the front drum as shown.

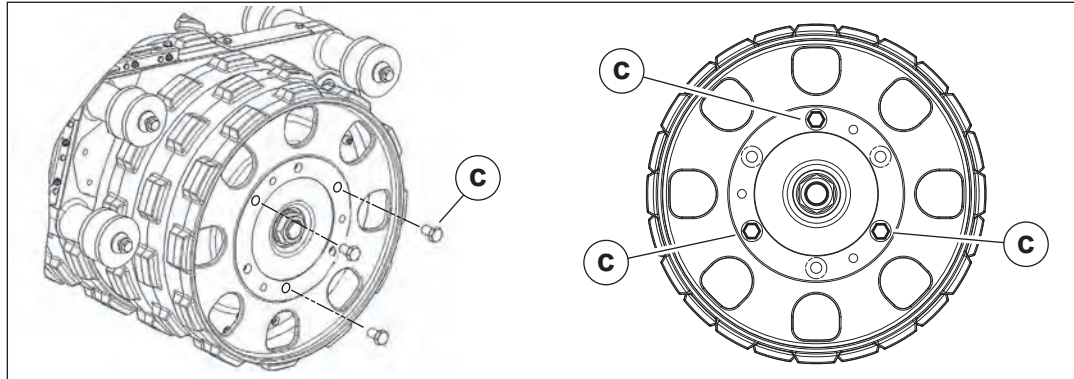

wc_gr010011

- Install a drum extension (b) on each end of the front drum. Align the mounting holes as shown in view "A" below.

Note: As you align the mounting holes, make sure the "sheep's foot" lugs on the drum and drum extension are offset from one another.

- Fasten the drum extension with (3) M16 x 80 screws (d) in the locations shown in views "A" and "B" below. Torque to 167 Nm (123 ft.lbs.).

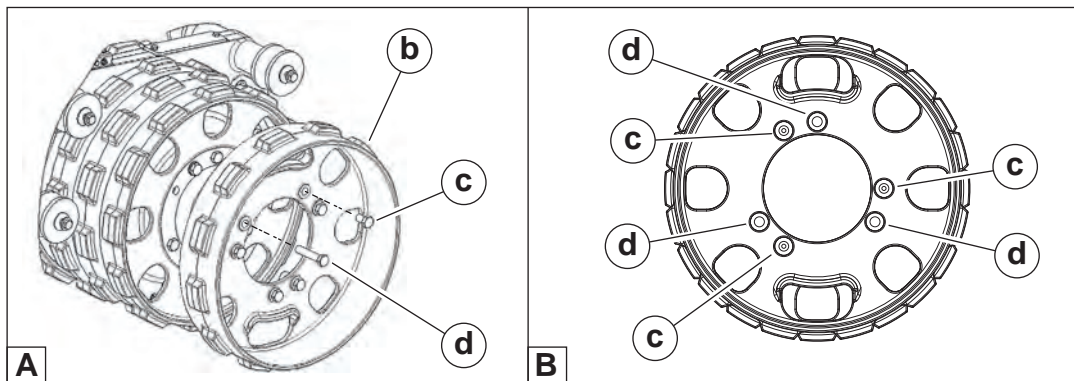

wc_gr009890

- Store (3) M16 x 25 screws (c) in the threaded "placeholder" holes as shown.

This procedure continues on the next page.

Continued from the previous page.

6. Install the wide scraper **(a)** using the screws **(g)** and washers **(h)** from Step 1. Torque the screws to 98 Nm (72 ft.lbs).

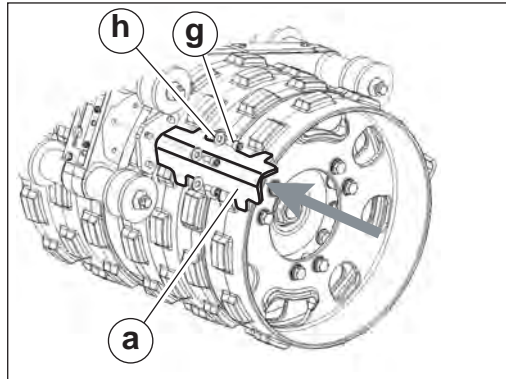

wc_gr009892

7. Repeat the installation procedure on the rear drum, beginning with Step 1.

Result

The drum extensions have now been installed.

7 General Maintenance

7.1 Periodic Maintenance Schedule

The table below lists basic machine maintenance. Tasks designated with check marks may be performed by the operator. Tasks designated with square bullet points require special training and equipment.

Roller	Daily before starting	Every 100 hours	Every 500 hours or 1 year	Every 1000 hours or 2 years
Check for loose or missing fasteners. Replace as needed.	✓			
Check hydraulic oil. Fill to correct level.	✓			
Clean control box / transmitter.	✓			
Verify that receiving eyes blink rapidly when approached by the operator.	✓			
Grease articulated joint.		✓		
Grease steering cylinder.		✓		
Change hydraulic system return line filter. ¹			■	
Change hydraulic fluid.				■

¹ Change after the first 100 hours of operation.

7.2 Hydraulic Oil Requirements

Wacker Neuson recommends the use of a good petroleum-based, anti-wear hydraulic oil in the hydraulic system of this equipment. Good anti-wear hydraulic oils contain special additives to reduce oxidation, prevent foaming, and provide for good water separation.

When selecting hydraulic oil for your machine, be sure to specify anti-wear properties. Most hydraulic oil suppliers will provide assistance in finding the correct hydraulic oil for your machine.

Avoid mixing different brands and grades of hydraulic oils.

Most hydraulic oils are available in different viscosities.

The SAE number for an oil is used strictly to identify viscosity—it **does not** indicate the type of oil (engine, hydraulic, gear, etc.).

When selecting a hydraulic oil be sure it matches the specified SAE viscosity rating and is intended to be used as a hydraulic oil. See section *Technical Data—Lubrication*.

7.3 Checking the Hydraulic Oil Level

A hydraulic oil level sight gauge **(a)** is located on the hydraulic reservoir inside the rear section of the machine.

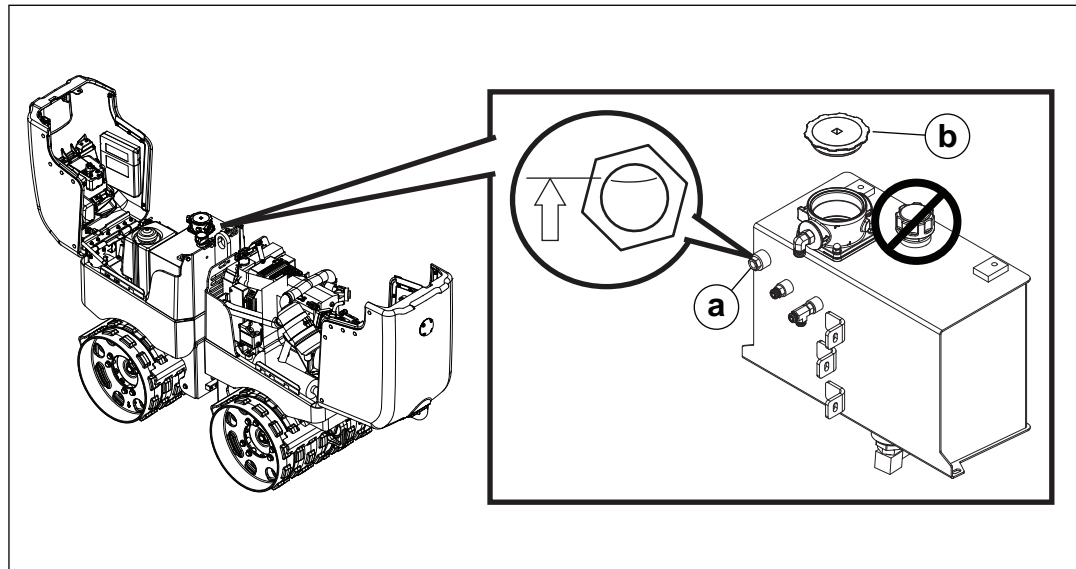

wc_gr012190

While the machine is turned off, check that the hydraulic oil level is visible at the middle level or higher in the sightglass. If it is not, add oil as required through the filter housing on top of hydraulic reservoir. Use only clean hydraulic oil.

Thoroughly clean the top of the filter cover **(b)** before removing it from the reservoir. Care should be taken to prevent small dirt particles from entering the system.

NOTICE

- If hydraulic oil continually needs to be added, inspect hoses and connections for possible leaks. Repair hydraulic leaks immediately to prevent damage to hydraulic components.
- Do not attempt to remove the vent cover from the hydraulic reservoir.

7.4 Changing Hydraulic Oil and Filter

- Requirements**
- Container of suitable size to collect oil
 - Fresh oil
 - New filter element

Note: *In the interests of environmental protection, place plastic sheeting and a container under the machine to collect the liquid which drains off. Dispose of this liquid properly.*

To change hydraulic oil:

1. Remove the drain plug **(a)** from bottom of frame and allow hydraulic fluid to drain.

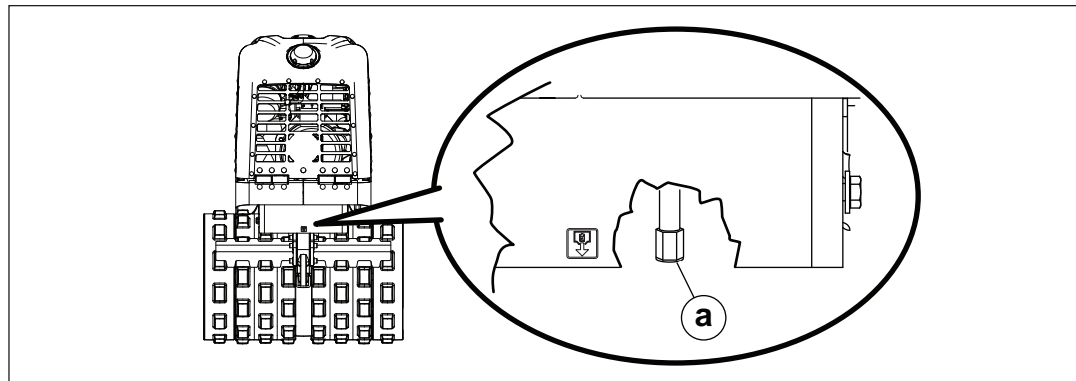

wc_gr012217

This procedure continues on the next page.

Continued from the previous page.

2. Clean the filter cover **(b)**.

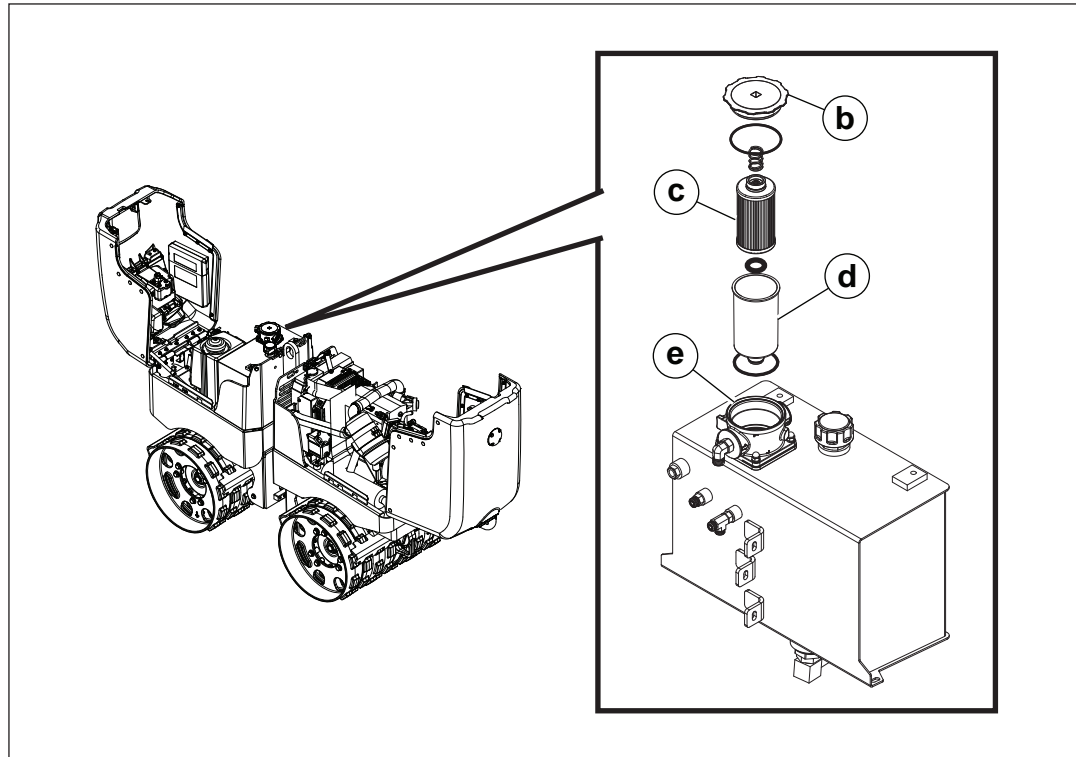

wc_gr012191

3. Remove the filter cover, and remove the filter element **(c)** and the lower filter housing **(d)**.

Note: As you remove the filter element and the lower filter housing, take care to note the proper location of all sealing O-rings.

NOTICE: To avoid machine damage, be extremely careful to avoid dropping anything into the reservoir housing **(e)** while the filter cover is off.

4. Re-install the drain plug.
5. Fill hydraulic tank through filter housing using clean hydraulic oil.
6. Install new filter element as shown in illustration.
7. Replace the O-rings, lower filter housing, and filter cover.

7.5 Lubricating the Articulated Joint and Steering Cylinders

Lubricate top and bottom bearing blocks **(a)** and cylinder knuckles **(b)** every 100 hours using a hand-held grease gun. Cylinder knuckles can be accessed through holes on side of machine **(c)**.

Use Mobil XHP222 or an equivalent No. 2 general purpose grease.

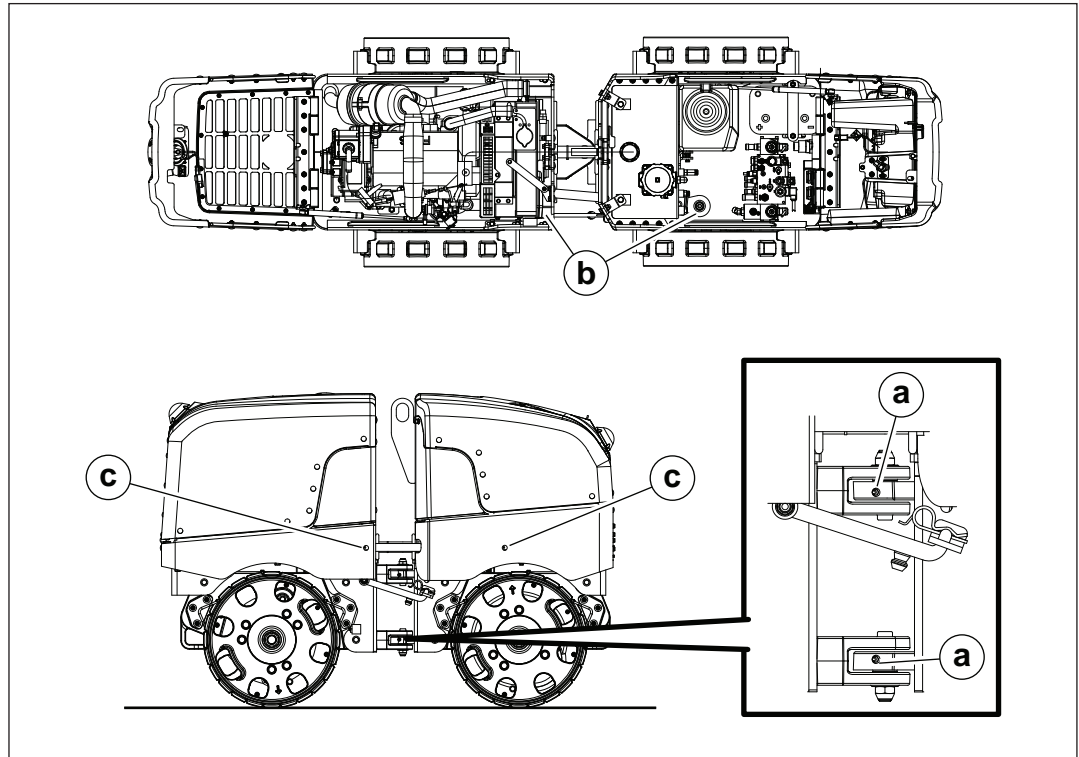

wc_gr012192

7.6 Cleaning SmartControl™ Transmitter

The transmitter and switches are completely sealed to keep dust and moisture out; however, contact with water should be kept to a minimum. Even a small amount of moisture can cause connections and contacts to corrode. Avoid immersing transmitter in water and do not clean using a pressure wash.

To clean the transmitter:

1. Wash off the transmitter using a damp cloth. Allow it to air dry.
2. To remove dirt and dust trapped around switches, use low-pressure compressed air.

7.7 Scraper Bars

Scraper bars **(a)** are provided on all four drums to prevent dirt from building up on the drum surfaces. These scrapers should be inspected and adjusted as required to remove as much dirt from the drums as possible.

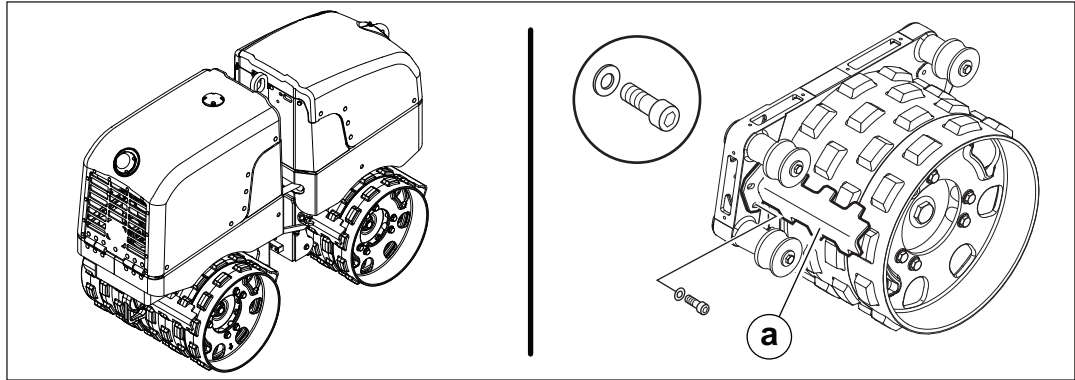

wc_gr012193

To adjust a scraper:

Loosen the three screws holding each scraper to the drum casting. Position the scraper 3–6 mm (1/8–1/4 in.) from the drum. Tighten screws and run machine to check that the scraper does not rub against the drum surface.

7.8 Shock Mounts

Inspect the drum shock mounts **(a)** every 300 hours for cracking, splitting or tearing. Replace shock mounts as needed.

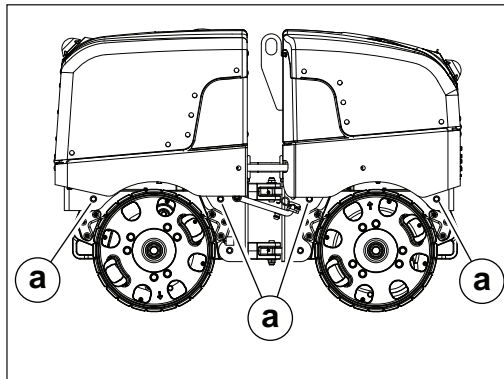

wc_gr012195

NOTICE: The shock mounts isolate the upper part of the machine from the heavy vibrations produced in the drums. Operating the machine with damaged shock mounts for an extended period of time may eventually damage other machine parts.

7.9 Maintaining the Battery

**WARNING**

Explosion hazard. Batteries can emit explosive hydrogen gas.

- ▶ Keep all sparks and flames away from the battery.
- ▶ Do not short-circuit battery posts.

Safety precautions

Observe the following safety precautions to prevent serious damage to the electrical system.

- Do not disconnect the battery while the machine is running.
- Do not attempt to run the machine without a battery.
- Do not attempt to jump-start the machine.
- In the event that the machine has a discharged battery, either replace the battery with a fully charged battery or charge the battery using an appropriate battery charger.
- Dispose of waste batteries in accordance with local environmental regulations.

Battery connections

To connect the battery:

1. Connect the red positive (+) battery cable to the battery.
2. Connect the black negative (-) battery cable to the battery.

To disconnect the battery:

1. Stop the engine.
2. Place all electrical switches in the OFF position.
3. Disconnect the black negative (-) battery cable from the battery.
4. Disconnect the red positive (+) battery cable from the battery.

Maintaining battery condition

- Follow the battery manufacturer's maintenance recommendations.
- Keep battery terminals clean and connections tight.
- When necessary, tighten the cables and grease the cable clamps with petroleum jelly.
- Maintain the battery at full charge to improve cold weather starting.

7.10 Draining the Fuel Filter Water Separator—Kohler Engine Only

Procedure Perform the procedure below to drain the fuel filter water separator.

1. Place a suitable collection container beneath the fuel filter **(a)**.

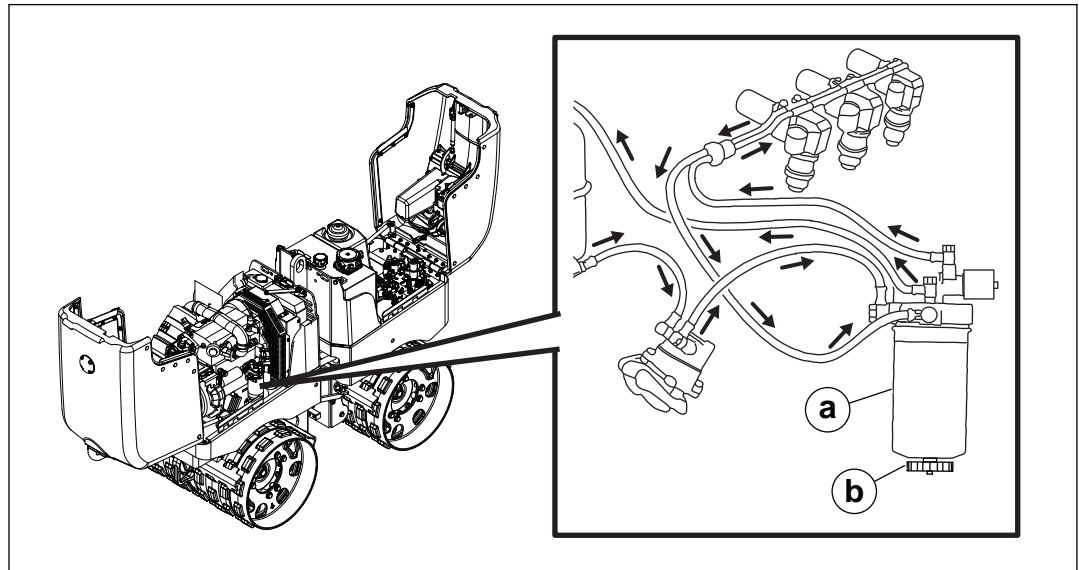

wc_gr012197

2. Loosen the cap **(b)** on the bottom of the fuel filter. This allows water and sediment to drain through the hole in the cap.
3. Tighten the cap.
4. Carefully remove the collection container and dispose of the contents in accordance with local environmental regulations.

7.11 Maintaining the Fuel Filter Water Separator—Kubota Engine Only

- Requirements**
- Engine is stopped
 - Suitable container to collect drained fuel/water
 - New filter

Draining the bowl

Perform the procedure below to drain the fuel filter water separator.

1. Locate the drain valve **(a)** on the fuel filter water separator.
2. Place a suitable collection container beneath the drain valve.
3. Open the drain valve by turning it counterclockwise. This will drain the fuel/water.
4. Close the drain valve when draining is complete.

Note: *Dispose of drained fuel/water in accordance with the local environmental protection regulations.*

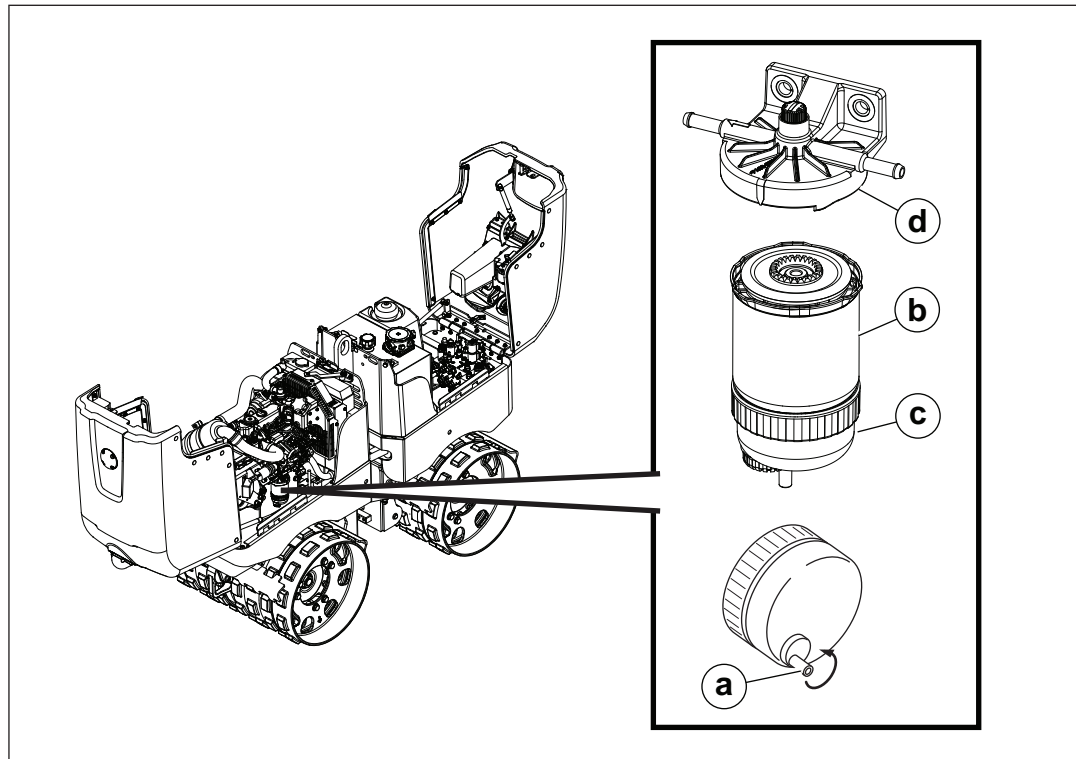

wc_gr012416

Changing the filter

Perform the procedure below to change the filter.

1. Pull the filter **(b)** and bowl **(c)** (as an assembly) off the housing **(d)**.
2. Unscrew the bowl from the filter. Discard the filter.
3. Install a new filter onto the housing.
4. Re-install the bowl.

7.12 Priming the Fuel System—Kohler Engine Only

If the fuel tank has been run completely dry or drained for service, it will be necessary to manually prime the fuel system.

To prime the fuel system:

1. Turn both the key switch on the machine, and the on-off switch on the control box, ON. This will open the fuel valve.
2. Loosen the bleed screw on the fuel filter and pump the lever on the fuel pump **(a)** until fuel flows freely from the bleed screw. Tighten the bleed screw.

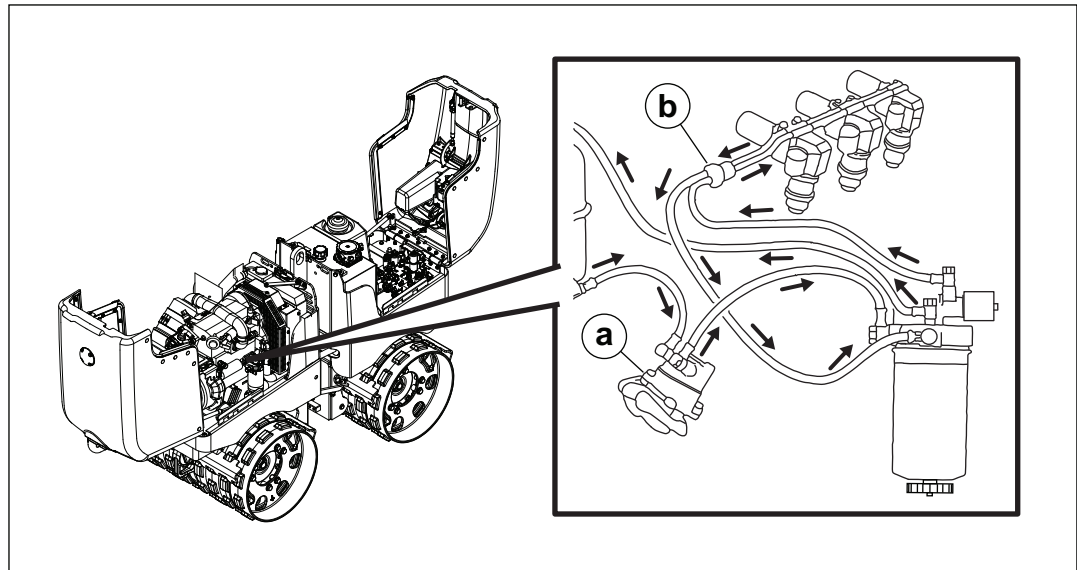

wc_gr012198

3. Repeat this procedure for the fuel line bleed screw **(b)**.

7.13 Storage

Do not allow the roller to sit overnight in a ditch, trench or other low-lying area which might fill with water during a heavy rain. Park the roller on a flat level surface, out of the way of traffic patterns and congestion. If the roller must be parked on an incline, chock the drums to prevent any chance of movement.

If leaving the roller on the job site, remove the key and lock the control panel cover and engine hood to prevent tampering. Both the front and rear hoods and access cover are equipped with a locking ring (a) for use with a padlock for this purpose.

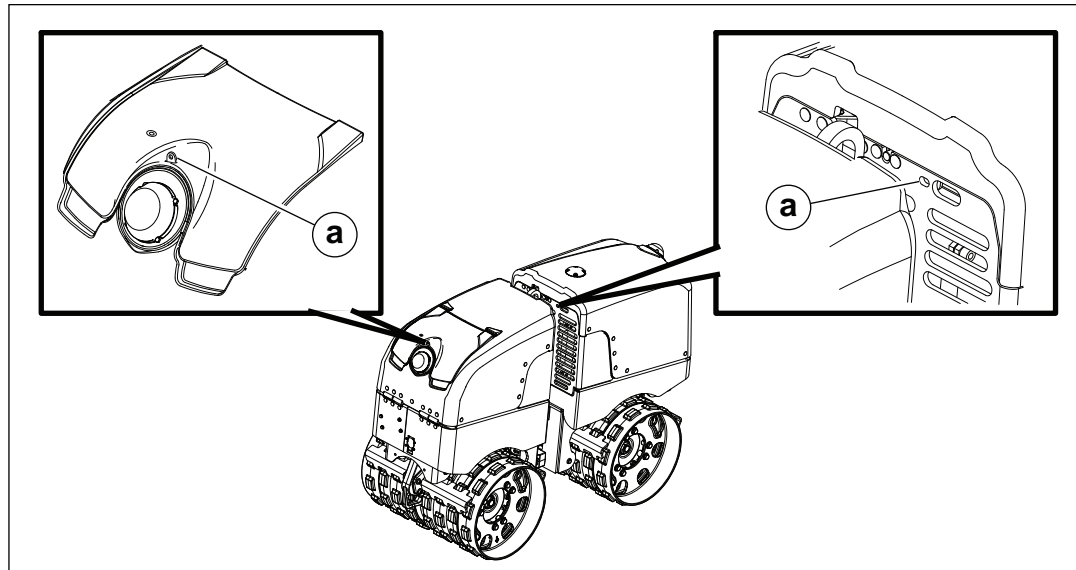

wc_gr012196

If desired, the SmartControl™ can be removed from the roller and stored separately.

7.14 Long-Term Storage

Introduction Extended storage of equipment requires preventive maintenance. Performing these steps helps to preserve machine components and ensures the machine will be ready for future use. While not all of these steps necessarily apply to this machine, the basic procedures remain the same.

When Prepare your machine for extended storage if it will not be operated for 30 days or more.

Preparing for storage Follow the procedures below to prepare your machine for storage.

- Complete any needed repairs.
- Replenish or change oils (engine, exciter, hydraulic, and gearcase) per the intervals specified in the Scheduled Maintenance table.
- Grease all fittings and, if applicable, repack bearings.
- Inspect engine coolant. Replace coolant if it appears cloudy, is more than two seasons old, or does not meet the average lowest temperature for your area.
- If your machine has an engine equipped with a fuel valve, start the engine, close the fuel valve, and run the engine until it stops.
- Consult the engine owner's manual for instructions on preparing the engine for storage.

Stabilizing the fuel After completing the procedures listed above, fill the fuel tank completely and add a high-quality stabilizer to the fuel.

- Choose a stabilizer that includes cleaning agents and additives designed to coat/protect the cylinder walls.
- Make sure the stabilizer you use is compatible with the fuel in your area, fuel type, grade and temperature range. Do not add extra alcohol to fuels which already contain it (for example, E10).
- For engines with diesel fuel, use a stabilizer with a biocide to restrict or prevent bacteria and fungus growth.
- Add the correct amount of stabilizer per the manufacturer's recommendations.

Storing the machine Perform these remaining steps to store your machine.

- Wash the machine and allow it to dry.
- Move the machine to a clean, dry, secure storage location. Block or chock wheels to prevent machine movement.
- Use touch-up paint as needed to protect exposed metal against rust.
- If the machine has a battery, either remove or disconnect it.

NOTICE: Allowing the battery to freeze or completely discharge is likely to cause permanent damage. Periodically charge the battery while the machine is not in use. In cold climates, store and charge the battery indoors or in a warm location.

- Cover the machine. Tires and other exposed rubber items should be protected from the weather. Either cover them or use a readily available protectant.

7.15 Machine Disposal / Decommissioning

Introduction This machine must be properly decommissioned at the end of its service life. Responsible disposal prevents toxic chemicals and materials from harming the environment. This machine contains several components that may be considered hazardous waste in many areas:

- Operating fluids, including fuel, engine oil, grease, and hydraulic fluid
- Batteries
- Electronic components, such as circuit boards, control panels, LEDs, and joysticks

Before decommissioning this machine, read and follow local safety and environmental regulations pertaining to the disposal of construction equipment.

Preparation Perform the following tasks to prepare the machine for disposal.

- Move the machine to a protected location where it will not pose any safety hazards and cannot be accessed by unauthorized individuals.
- Ensure that the machine cannot be operated from the time of final shutdown to disposal.
- Drain all fluids, including fuel, engine oil, and hydraulic fluid.
- Seal any fluid leaks.
- Remove the battery.

Disposal Perform the following tasks to dispose of the machine.

- Disassemble the machine and separate all parts by material type.
- Dispose of recyclable parts as specified by local regulations.
- Dispose of all non-hazardous components that cannot be recycled.
- Dispose of waste fuel, engine oil, and hydraulic fluid in accordance with local environmental protection regulations.

8 Engine Maintenance: Kohler (T4f)

The information in this chapter comes from copyrighted Kohler material.

The viscosity of the engine oil is an important factor when determining the correct engine oil to use in your machine. Use an engine oil of appropriate viscosity based on the expected outside air temperature. See the table below.



WARNING

Most used liquids from this machine such as oil, gasoline, grease, etc., contain small amounts of materials that can cause cancer and other health problems if inhaled, ingested, or left in contact with skin for prolonged periods of time.

- ▶ Take steps to avoid inhaling or ingesting used liquids.
- ▶ Wash skin thoroughly after exposure to used liquids.

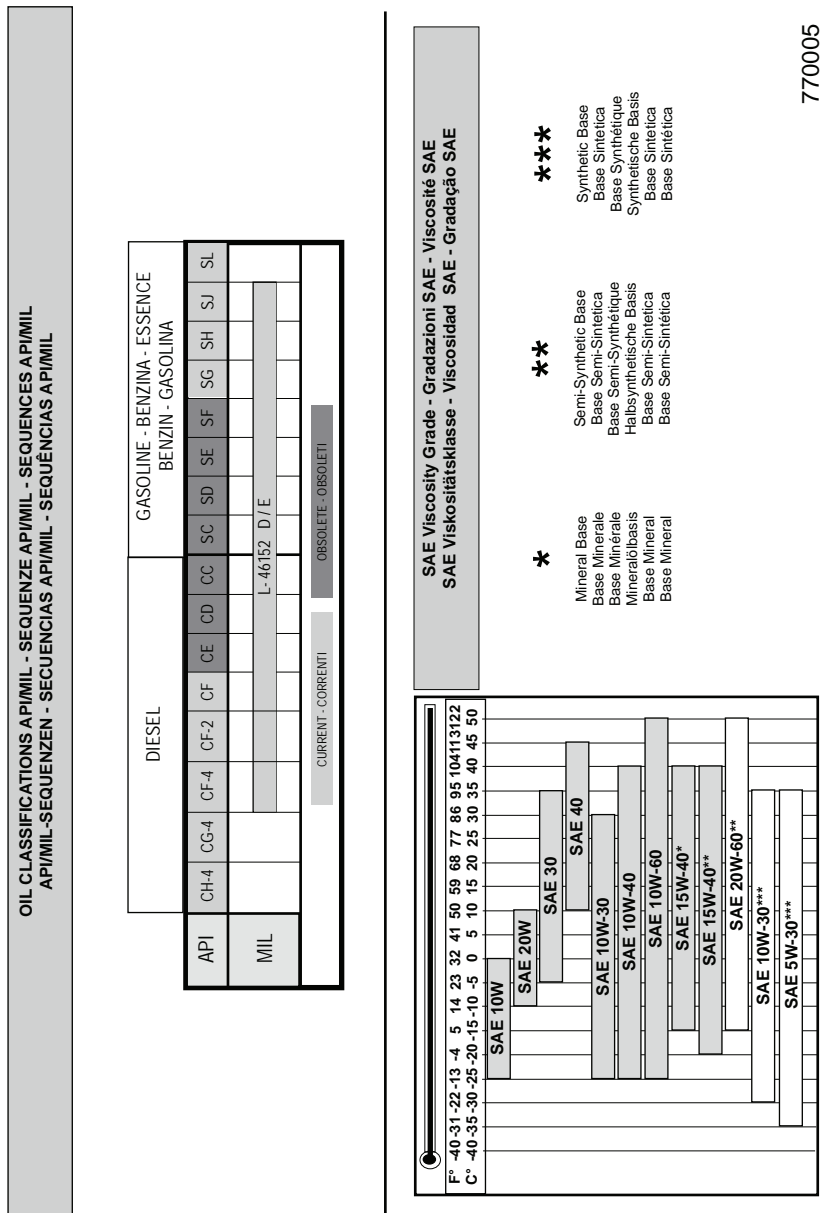

7770005

The engine maintenance schedule(s) in this chapter are reproduced from the engine owner's manual. For additional information, see the engine owner's manual.

ORDINARY MAINTENANCE - MANUNTENZIONE ORDINARIA ENTRETIEN ORDINAIRE - ORDENTLICHE WARTUNG MANUTENCION ORDINARIA - MANUNTENNAÇÃO NORMAL		CHECK - CONTROLLO - CONTRÔLE - KONTROLLE - COMPROBACION - CONTRÔLE						
		OPERATION DESCRIPTION - DESCRIZIONE OPERAZIONE DESCRIPTION DE L'OPERATION - BESCHREIBUNG DES ARBEITSVORGANGS DESCRIPCION DE LA OPERACION - DESCRICÃO DA OPERAÇÃO		FREQUENCY x HOURS - PERIODICITA' x ORE FREQUENCIA x HEURES - WARTUNGSPERIODEN x STUNDEN PERIODO x HORAS - FREQUÊNCIA x HORAS				
		10	250	300	500	1000	5000	10000
Oil Level - Livello Olio Motore - Niveau huile Moteur - Ölstanddaten - Nivel Aceite Del Motor - Nivel Óleo do Motor								
Coolant Level - Livello Liquido di Raffreddamento - Niveau Liquide Réfrigérant - Kühlfüssigkeitsstands - Nivel Liquido para Refrigeración - Nivel Liquido Esfriamento.								
Radiator Core - Superficie di Scambio Radiatore - Surface d'Échange radiateur - Austauschfläche des Kühlers - Superficie de Intercambio del Radiador - Superficie de Troca do Radiador								
Panel Air Filter (Dry-Type) - Filtro Aria a Pannello (a Secco) - Filtre à Air à Panneau (à Sec) - Plattenluftfilter (Trocken) - Filtro de Aire de Panel (a Seco) - Filtro de Ar de Painel (a Seco)	(**)							
Remote Air Filter (Dry-Type) - Filtro Aria a Distanza (a Secco) - Filtre à Air à Distance (à Sec) - Luftfilter Mit Abstand (Trocken) - Filtro de Aire Remoto (a Seco) - Filtro de ar a Distância (a Seco)	(**)							
Fuel Lines - Tubi Carburante - Tuyaux Combustible - Kraftstoffleitungen - Tubos de Combustible - Tubos Combustíveis								
Fan/Alternator Belt Tension - Tensione Cinghia Ventola/Alternatore - Tension Courroie Ventilateur/Alternateur Keilriemens Lüfter - Tensión Correa Ventilador/Alternador - Tensão Cincha Ventilador/Alternador	(*)							

(***) - Check paper element for dirty, loose, or damaged parts, in accordance with the maintenance schedule. Depending on the environment the engine is used in, clean and replace filter more often, especially in dusty, dirty conditions.

- Il periodo di tempo che deve intercorrere prima di pulire o sostituire l'elemento filtrante è subordinato all'ambiente in cui opera il motore. In condizioni ambientali molto polverose il filtro dell'aria deve essere pulito e sostituito più spesso.
- Le temps qui doit s'écouler avant de nettoyer ou de remplacer l'élément filtrant dépend des conditions dans lesquelles le moteur tourne. Nettoyer et remplacer plus souvent le filtre à air doit quand le milieu est très poussiéreux.
- Das Zeitintervall zwischen den Reinigungen oder dem Auswechseln des Filterelements hängt von der Umgebung ab, in der der Motor verwendet wird. In sehr staubiger Umgebung muss der Luftfilter öfter gereinigt und ausgetauscht werden.
- El intervalo de tiempo que debe transcurrir antes de limpiar o sustituir el elemento filtrante depende del ambiente de funcionamiento del motor. En ambientes muy polvorientos el filtro de aire debe ser limpio y debe sustituirse más a menudo.
- O período de tempo que há de passar antes de limpar ou substituir o elemento filtrante está subordinado ao ambiente em que o motor trabalha. Em condições ambientais muito poeirentas o filtro do ar deve ser limpo e substituído muitas vezes.

770002

CHECK - CONTROLLO - CONTRÔLE - KONTROLLE - COMPROBACION - CONTRÔLE							
OPERATION DESCRIPTION - DESCRIZIONE OPERAZIONE DESCRIPTION DE L'OPÉRATION - BESCHREIBUNG DES ARBEITSVORGANGS DESCRIPCIÓN DE LA OPERACION - DESCRIÇÃO DA OPERAÇÃO	FREQUENCY x HOURS - PERIODICITA' x ORE FREQUENCE x HEURES - WARTUNGSPERIODEN x STUNDEN PERIODO x HORAS - FREQUÊNCIA x HORAS						
	10	250	300	500	1000	5000	10000
Cooling Hoses - Manicotti Liquido di Raffreddamento - Manchons de Liquide de Refroidissement - Muffen des Kühlmittels - Manguitos de Liquido de Refrogeración - Casquilhos para Liquido de Arrefecimento							
Rubber Intake Hose (Air Filter and Intake Manifold) for Engines with Remote Air Filter - Tubo in Gomma Asp. (Filtro Aria Coll. Asp.) Per Mot. Con Filtro Aria a Dist. - Tuyau d'Aspiration en Caoutchouc (Filtre à Air du Collecteur d'Admission) Pour Mot. Avec Système de Filtrage d'Air à Distance - Gummiansaugschlauch (Luftfilter Ansaugkrümmer) Für Mot. Mit Luftfilter Mit Abstand - Tubo de Goma de Dimensión (Filtro de Aire Colector de Admisión) Para Mot. Con Filtro de Aire Remoto - Tubo de Borracha de Aspiração (Filtro ar Colector de Aspiração) Para Mot. com Filtro de ar a Distância							
Valve Clearance - Registro Gioco Valvole - Réglage Jeu Soupapes - Einstellen des Ventilspiels Ajuste da Tolarância - Registro Juego de Válvulas - Apuramento válvula							
Injector Cleaning and Adjustment - Taratura e Pulizia Iniettori - Tarage et Nettoyage Injecteur Einspritzdüsen Überprüfen - Ajuste y Limpieza Inyectores - Taradura e Limpeza Injectores							
Flush Radiator - Pulizia Interna Radiatore - Nettoyage Intérieur du Radiateur - Innenreinigung des Kühlers - Limpeza del Interior del Radiador - Limpeza Interna do Radiador							
Clean Fuel Tank - Pulizia Serbatoio Combustibile - Nettoyage du Réservoir à Combustible - Reinigung Kraftstofftank - Limpeza Depósito Combustible - Limpeza do Depósito do Combustível							

770003

REPLACEMENT - SOSTITUZIONE - REMPLACEMENT - AUSWECHSELN - SUBSTITUCIÓN - SUBSTITUIÇÃO		FREQUENCY x HOURS - PERIODICITA' x ORE						
		FREQUENCY x HOURS - PERIODICITA' x ORE PERIODO x HORAS - FRECUENCIA x HORAS						
OPERATION DESCRIPTION - DESCRIZIONE OPERAZIONE DESCRIPTION DE L'OPERATION - BESCHREIBUNG DES ARBEITSVORGANGS DESCRIPCION DE LA OPERACION - DESCRICAO DA OPERACAO		10	250	300	500	1000	5000	10000
Engine Oil (*) - Olio Motore (*) - Huile Moteur (*) - Öldaten (*) - Aceite del Motor (*) - Óleo do Motor (*)		(*)						
Oil Filter - Filtro Olio - Filtre a Huile - Öl Filter - Filtro Aceite - Filtro Óleo		(*)						
Fuel Filter - Filtro Combustibile - Filtre a Combustible - Brennstofffilter - Filtro Combustible - Filtro Combustível		(*)						
Alternator Belt - Cinghia Alternatore - Courroie Alternateur - Drehstromgenerator Riemen - Correa Alternador - Cincha Alternador		(**)						
Coolant - Liquido di Raffreddamento - Liquide Refrigerant - Kühflüssigkeit - Líquido de Refrigeración - Líquido Esfriamento		(**)						
Fuel Lines - Tubi Carburante - Tuyaux Combustible - Kraftstoffleitungen - Tubos de Combustible - Tubos Combustíveis		(**)						
Rubber Intake Hose (Air Filter and Intake Manifold) - Tubo in Gomma Asp. (Filtro Aria Coll. Asp.) - Tuyau d'aspir. en Caoutchouc (Filtre à Air du Coll. d'Admiss.) - Gummiansaugschlauch (Luftfilter Ansaugtrümmer) - Tubo de Goma de Admis. (Filtro de Aire Col. De Admis.) - Tubo de Borracha de Aspir. (Filtro ar Col. de Aspir.)		(**)						
Coolant Hoses - Manicotti Liquido di Raffredd. - Manchons de Liquide de Refroid. - Muffen des Kühlmittels - Manguitos de Líquido de Refrig. - Casquilhos para Líquido de Arrefecimento		(**)						
Timing Belt - Cinghia Distribuzione - Courroie de Distribution - Verteilerriemen Correa de Distribución - Correia de Distribuição		(***)						
Dry Air Cleaner, External Cartridge - Cartuccia Esterna Filtro Aria a Secco - Cartouche Extérieure Filtre a Air Desséchée - Äusserer Trockenluftfiltersatz - Cartucho Externo del Filtro de Aire Seco - Cartucho Externo Filtro ar A Seco		(****)						
Filter Element, Panel Air Filter - Massa Filtrante Filtro Aria a Pannello - Masse Filtrante de Filtre à Air à Panneau Filtrerelement Plattenluftfilter - Masa Filtrante del Filtro de Aire de Panel - Massa Filtrante do Filtro de ar de								After six cleaning checks - Dopo 6 Controlli con Pulizia - Au Bout de 6 Contrôles Avec Nettoyage - Nach 6 Kontrollen Mit Reinigung - Tras 6 Inspecciones Con Limpieza - Após 6 Controles com Limpeza

- (°) - If you are using oil of a quality lower than the prescribed one then you will have to replace it every 125 hours for the standard sump and every 150 hours for the enhanced sump.
- Se si utilizza olio di qualità inferiore a quello prescritto sostituirlo ogni 125 ore per la coppa standard e 150 per la coppa maggiorata.
 - Si l'huile utilisée est de qualité inférieure à celle indiquée, la vidanger toutes les 125 heures s'il s'agit d'un carter standard et toutes les 150 heures s'il s'agit d'un carter surdimensionné.
 - Wenn Öl einer niedrigeren Qualität als vorgeschrieben verwendet wird, sollte es bei Standardölwannen alle 125 Betriebsstunden, bei vergrößerten Ölwannen alle 150 Stunden gewechselt werden.
 - Si se utiliza un aceite de calidad inferior al que recomendado deberá sustituirse cada 125 horas en caso de cárter estándar o cada 150 en caso de cárter sobredimensionado.
 - Se utilizar óleo de qualidade inferior à queles prescrito, substitua-o a cada 125 horas para o cárter padrao e 150 para o cárter aumentado.

770004

9 Engine Maintenance: Kubota D902

The viscosity of the engine oil is an important factor when determining the correct engine oil to use in your machine. Use an engine oil of appropriate viscosity based on the expected outside air temperature. See the table below.



WARNING

Most used liquids from this machine such as oil, gasoline, grease, etc., contain small amounts of materials that can cause cancer and other health problems if inhaled, ingested, or left in contact with skin for prolonged periods of time.

- ▶ Take steps to avoid inhaling or ingesting used liquids.
- ▶ Wash skin thoroughly after exposure to used liquids.

Oil Viscosity

IMPORTANT :

- Engine oil should be MIL-L-2104C or have properties of API classification CF or higher.
Change the type of engine oil according to the ambient temperature.

Above 25°C (77°F)	SAE30 or SAE10W-30 SAE15W-40
-10°C to 25°C (14°F to 77°F)	SAE10W-30 or SAE15W-40
Below -10°C (14°F)	SAE10W-30

- When using oil different from the previous one, be sure to drain all the previous oil before adding the new engine oil.

770059

Engine Maintenance: Kubota D902

The engine maintenance schedule(s) in this chapter are reproduced from the engine owner's manual. For additional information, see the engine owner's manual.

MAINTENANCE

SERVICE INTERVALS

Observe the following for service and maintenance.

Interval	Item	Ref. page		
Every 50 hours	Check of fuel pipes and clamp bands	13		@
See NOTE	Change of engine oil (depending on the oil pan)	14,15	◎	
Every 100 hours	Cleaning of air cleaner element	19	*1	@
	Cleaning of fuel filter	14		
	Check of fan belt tightness	20		
	Draining water separator	-		
Every 200 hours	Replacement of oil filter cartridge (depending on the oil pan)	16	◎	
	Check of intake air line	-		@
Every 200 hours of operation or six months	Check of radiator hoses and clamp bands	18		
Every 400 hours	Replacement of fuel filter element	14		@
	Cleaning of water separator in fuel tank	-		
Every 500 hours	Cleaning of water jacket (radiator interior)	-		
	Replacement of fan belt	20		
Every year or every 6 cleanings of air cleaner element	Replacement of air cleaner element	19	*2	@
Every 800 hours	Check of valve clearance	-	*3	
Every 1500 hours	Check of fuel injection nozzle injection pressure	-	*3	@
Every 3000 hours	Check of injection pump	-	*3	@
Every two years	Replacement of radiator hoses and clamp bands	18		
	Replacement of fuel pipes and clamps	13	*3	@
	Change of radiator coolant (L.L.C.)	16		
	Replacement of intake air line	-	*4	@

IMPORTANT :

- The jobs indicated by ◎ must be done after the first 50 hours of operation.
- *1 Air cleaner should be cleaned more often in dusty conditions than in normal conditions.
- *2 After 6 times of cleaning.
- *3 Consult your local KUBOTA Dealer for this service.
- *4 Replace only if necessary.
- The items listed above (@ marked) are registered as emission related critical parts by KUBOTA in the U.S. EPA nonroad emission regulation. As the engine owner, you are responsible for the performance of the required maintenance on the engine according to the above instruction. Please see the Warranty Statement in detail.

770060

Engine Maintenance: Kubota D902

NOTE :

- Changing interval of Engine oil and oil filter cartridge.

		*Oil pan depth	
		*101 mm (3.98 in.)	121 mm (4.76 in.)
Z602-E4 D902-E4	Engine oil	50 Hrs (Initial)	-
		100 Hrs	
	Oil filter cartridge	200 Hrs	
Z482-E4 D722-E4	Engine oil	50 Hrs (Initial)	
		75 Hrs	100 Hrs
	Oil filter cartridge	150 Hrs	200 Hrs
D782-E4	Engine oil	-	50 Hrs (Initial)
			100 Hrs
	Oil filter cartridge		200 Hrs

* 101 mm (3.98 in.) oil pan depth is optional for Z482-E4 and D722-E4.

**Standard replacement interval

- American Petroleum Institute (API) classification: above CF-4 grade
- Ambient temperature: below 35°C (95°F)

770061

NOTICE: Synthetic oil can be used with Kubota powered machines. When using synthetic oil, the oil change interval is 500 hours.

10 Troubleshooting

Problem	Reason	Remedy
Engine does not start	Fuel tank empty	Fill with No. 2 diesel fuel and prime fuel lines.
	Wrong type of fuel	Drain tank, change fuel filter, and fill with fresh fuel.
	Water in fuel	Drain water from fuel filter.
	Old fuel	Drain tank, change fuel filter, and fill with fresh fuel.
	Fuel system not primed	Prime fuel system.
	Fuel filter restricted or clogged	Replace fuel filter.
	Battery connections loose or corroded	Check connections. Tighten or clean as needed.
	Discharged battery	Charge or replace battery.
	Engine oil level too low	Add engine oil.
	Air cleaner element clogged	Maintain air cleaner.
	Faulty starter motor	Repair or replace.
	Faulty starter button on control box or transmitter	Repair or replace.
	Inoperative fuel valve solenoids on engine (Kohler powered machines only)	Repair or replace.
	Inoperative stop solenoid on engine (Kubota powered machines only)	Repair or replace.
	Inoperative starter relay	Repair or replace.
	Electrical connections loose or broken	Check connections; repair or replace.
	Machine out of infra-red signal range	Move transmitter closer to machine.
	Transmitter and decoder channels are different	Set transmitter and decoder to the same channel.
Communication fault	See topic <i>Communication Faults</i> .	
Engine starts, then stops	Fuel tank empty	Fill with No. 2 diesel fuel and prime fuel lines.
	Fuel filter restricted or clogged	Replace fuel filter.
	Fuel lines broken or loose	Check fuel lines; tighten, repair or replace as needed
	Machine out of infra-red range.	Move transmitter closer to machine.
	Transmitter automatically powered off due to inactivity	Turn on transmitter.

Problem	Reason	Remedy
No vibration	Machine in high speed travel mode	Reduce machine speed, then press vibration switch.
	Faulty vibration switch or poor connection inside transmitter	Check connection; repair or replace as needed.
	Inoperative solenoid on vibration valve	Repair or replace.
	Damaged exciter assembly	Repair or replace.
	Damaged exciter motor coupling	Repair or replace.
	Damaged exciter motor	Repair or replace.
	Damaged exciter pump	Repair or replace.
	Machine out of infra-red signal range	Move transmitter closer to machine.
	Operator too close to machine	Move away from machine.
	Communication fault	See topic <i>Communication Faults</i> .
No travel, or travel only in one direction	Faulty forward/reverse switch or poor connection inside transmitter	Check connection; repair or replace as needed.
	Inoperative solenoid on travel valve	Repair or replace.
	Damaged drive gearcase assembly	Repair or replace.
	Loose, broken or corroded wire connections inside control panel or transmitter	Repair or replace.
	Damaged drive motor	Repair or replace.
	Damaged drive pump	Repair or replace.
	Machine out of infra-red signal range	Move transmitter closer to machine.
	Operator too close to machine	Move away from machine.
	Communication fault	See topic <i>Communication Faults</i> .
No high speed travel	Faulty forward/reverse switch or poor connection inside transmitter	Check connection; repair or replace as needed.
	Inoperative solenoid on manifold	Repair or replace.
	Loose, broken or corroded wire connections inside control panel or transmitter	Repair or replace.
	Damaged exciter pump	Repair or replace.
	Vibration is turned on	Turn off vibration.
	Machine out of infra-red signal range	Move transmitter closer to machine.
	Operator too close to machine	Move away from machine.
	Communication fault	See topic <i>Communication Faults</i> .

Problem	Reason	Remedy
No steering	Faulty left/right joystick switch or poor connection inside transmitter	Check connection; repair or replace as needed.
	Inoperative solenoid on steering valve	Repair or replace.
	Loose, broken or corroded wire connections inside control panel or transmitter	Repair or replace.
	Damaged steering cylinder	Repair or replace.
	Locking bar engaged	Disengage locking bar.
	Machine out of infra-red signal range	Move transmitter closer to machine.
	Operator too close to machine	Move away from machine.
	Communication fault	See topic <i>Communication Faults</i> .

11 Technical Data

11.1 Engine

Machine		RT82-SC3 / RTx-SC3	
Engine type		3-cylinder, 4-cycle, liquid-cooled, diesel engine	
Engine make		Kohler	Kubota
Engine model		KDW 1003	D902
Rated power ¹	kW (hp)	13.9 (18.6) @ 2,600 rpm	15.5 (20.5) @ 3,000 rpm
Emission standard category		Tier 4	
Alternator	A / V	23.8 / 16.5 @ 2,600 rpm	40.0 / 12.0
Engine speed - full load	rpm	2,600	3,000
Engine speed - idle	rpm	1,300	1,450
Valve clearance (cold) intake: exhaust:	mm (in.)	0.15 (0.006) 0.20 (0.008)	0.15 (0.006) 0.19 (0.007)
Air cleaner	type	Dry pleated paper elements	
Battery	V / ccA	12V - Sealed / 800	
Fuel	type	No. 2 Diesel Low sulfur or ultra low sulfur fuel only	
Fuel tank capacity	L (gal)	24.0 (6.3)	
Fuel consumption	L (gal)/hr	4.5 (1.2)	
Radiator capacity	L (gal)	4.75 (1.25)	

¹Net power rating per ISO 3046/1. Actual power output may vary due to conditions of specific use.

11.2 Roller

Machine		RTx-SC3		RT82-SC3
		Narrow	Wide	—
Operating weight (Kohler)	kg (lb)	1,363 (3,005)	1,495 (3,295)	1,450 (3,197)
Operating weight (Kubota)	kg (lb)	1,335 (2,945)	1,467 (3,235)	1,422 (3,134)
Area capacity	m ² (ft ²) / hr	676 (7,276)	990 (10,654)	990 (10,654)
Inside turning radius	m (in.)	1.73 (68)	1.6 (63)	1.6 (63)
Travel speed	m (ft)/min	41.66 (132) high 21.66 (66) low		
Vibration frequency	Hz (vpm)	41.7 (2500)		
Gradeability with vibration	%	50		
Gradeability w/o vibration	%	45		

11.3 Lubrication

Machine:		RT82-SC3 / RTx-SC3
Engine crankcase (Kohler powered machines only)	type L (qt)	SAE 15W40 Class CF rated or synthetic oil 2.5 (2.6)
Engine crankcase (Kubota powered machines only)	type L (qt)	SAE 15W40 Class CF rated or synthetic oil ¹ 3.0 (3.2)
Hydraulic system	type L (gal)	Premium grade, anti-wear hydraulic fluid SAE 10W30 40 (8)
Articulated joint	type qty	Mobil SHC 220 grease as required
Steering cylinder	type qty	Mobil SHC 220 grease as required
Radiator	type qty %	Water / Glycol 50 / 50
Exciter / drive bearings	type	Mobil SHC 220 grease
Drive gear / seals	type	Mobil SHC 220 grease

¹Use synthetic oil to achieve 500 hour oil change interval for Kubota powered machine.

11.4 Sound and Vibration Specifications

Products are tested for sound pressure level in accordance with EN ISO 11204. Sound power level is tested in accordance with European Directive 2000/14/EC - Noise Emission in the Environment by Equipment for use outdoors.

The sound pressure level at operator's location (L_{pA}) = 83 db(A).

The guaranteed sound power level (L_{WA}) = 109 db(A).

Because this machine is operated using remote control the operator is not exposed to vibration.

11.5 Dimensions

mm (in.)

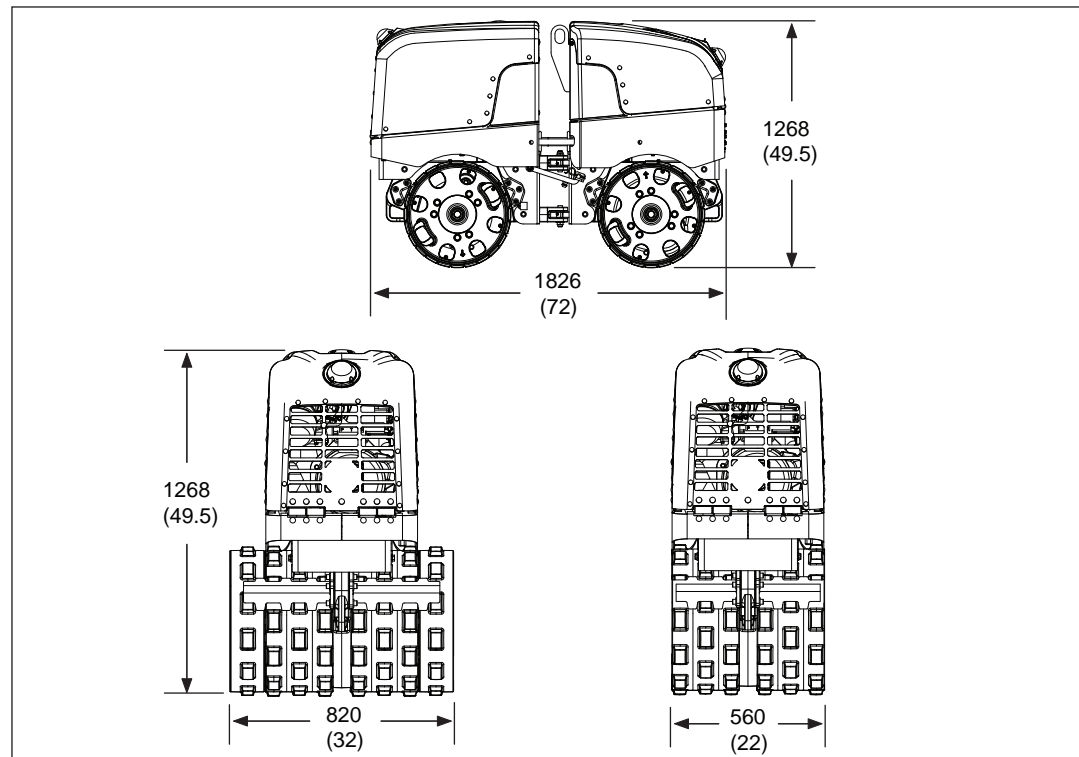

wc_gr012214

11.6 Radiation Compliance

This machine meets the radio interference radiated emission requirements of European Standard EN 13309 for Construction Machinery.

Notes

12 Emission Control Systems Information and Warranty—Diesel

The Emission Control Warranty and associated information is valid only for the U.S.A., its territories, and Canada.

12.1 Emission Control System Background Information

Introduction

Wacker Neuson engines/equipment must conform with applicable Environmental Protection Agency (EPA) and California Air Resource Board (CARB) emissions regulations. These regulations require that manufacturers warrant the emission control systems for defects in materials and workmanship.

Furthermore, EPA and CARB regulations require all manufacturers to furnish written instructions describing how to operate and maintain the engines/equipment including the emission control systems. This information is provided with all Wacker Neuson engines/equipment at the time of purchase.

Exhaust Emissions

The combustion process produces carbon monoxide, oxides of nitrogen, and hydrocarbons. Control of hydrocarbons and oxides of nitrogen is very important because, under certain conditions, they react to form photochemical smog when subjected to sunlight. Carbon monoxide does not react in the same way, but it is toxic.

Problems that may affect Emissions

If any of the following symptoms arise, have the engine/equipment inspected and repaired by a Wacker Neuson dealer/service center.

- Hard starting or stalling after starting
 - Rough idling
 - Misfiring or backfiring under load
 - Afterburning (backfiring)
 - Presence of black exhaust smoke during operation
 - High fuel consumption
-

Tampering and Altering

Tampering with or altering the emission control system may increase emissions beyond the legal limit. If evidence of tampering is found, Wacker Neuson may deny a warranty claim. Among those acts that constitute tampering are:

- Removing or altering of any part of the air intake, fuel, or exhaust systems.
- Altering or defeating the speed-adjusting mechanism causing the engine to operate outside its design parameters.

12.2 Limited Defect Warranty for Exhaust Emission Control System

See the supplied engine owner's manual for the applicable emission warranty statement.

12.3 Limited Defect Warranty for Wacker Neuson Emission Control Systems

The Emission Control Warranty is valid only for the U.S.A., its territories, and Canada.

Wacker Neuson Sales Americas, LLC, N92 W15000 Anthony Avenue, Menomonee Falls, WI 53051, (hereinafter "Wacker Neuson") warrants to the initial retail purchaser and each subsequent owner, that this engine/equipment, including all parts of its emission control system, have been designed, built, and equipped to conform at the time of initial sale to all applicable evaporative emission regulations of the U.S. Environmental Protection Agency (EPA) and the California Air Resources Board (CARB), and that the engine/equipment is free of defects in materials and workmanship which would cause this engine/equipment to fail to conform to EPA regulations during its warranty period.

Wacker Neuson is also liable for damages to other engine/equipment components caused by a failure of any warranted parts during the warranty period.

Limited Defect Warranty Period for Wacker Neuson Emission Control Systems

The warranty period for this engine/equipment begins on the date of sale to the initial purchaser and continues for a period of five years or 3000 hours of operation (whichever comes first). For the warranty terms for your specific engine/equipment, visit wackerneuson.com.

Any implied warranties are limited to the duration of this written warranty.

What is covered

Wacker Neuson recommends the use of genuine Wacker Neuson parts, or the equivalent, whenever maintenance is performed. The use of replacement parts not equivalent to the original parts may impair the effectiveness of the engine/equipment emission controls systems. If such a replacement part is used in the repair or maintenance of the engine/equipment, assure yourself that such part is warranted by its manufacturer to be equivalent to the parts offered by Wacker Neuson in performance and durability. Furthermore, if such a replacement part is used in the repair or maintenance of the engine/equipment, and an authorized Wacker Neuson dealer/service center determines it is defective or causes a failure of a warranted part, the claim for repair of the engine/equipment may be denied. If the part in question is not related to the reason the engine/equipment requires repair, the claim will not be denied.

Emission Control Systems Information and Warranty—Diesel

For the components listed in the following table, an authorized Wacker Neuson dealer/service center will, at no cost to you, make the necessary diagnosis, repair, or replacement necessary to ensure that the engine/equipment complies with the applicable EPA regulations. All defective parts replaced under this warranty become property of Wacker Neuson.

System Covered	Components
Air filter system and associated plumbing (Before engine intake)	Air filter
	Air filter plumbing
Exhaust system connected after the Exhaust Manifold	Exhaust gas piping and muffler connected to the Exhaust Manifold

What is not covered

- Failures other than those resulting from defects in material or workmanship.
- Any systems or parts which are affected or damaged by owner abuse, tampering, neglect, improper maintenance, misuse, improper fueling, improper storage, accident and/or collision; the incorporation of, or any use of, add-on or modified parts, or unsuitable attachments, or the alteration of any part.
- Replacement of expendable maintenance items made in connection with required maintenance services after the item's first scheduled replacement as listed in the maintenance section of the engine/equipment operator's manual, such as spark plugs and filters.
- Incidental or consequential damages such as loss of time or the use of the engine/equipment, or any commercial loss due to the failure of the engine/equipment.
- Diagnosis and inspection charges that do not result in warranty-eligible service being performed.
- Any non-authorized replacement part, or malfunction of authorized parts due to use of non-authorized parts.

Owner's Warranty Responsibility

The engine/equipment owner, is responsible for the performance of the required maintenance listed in the Wacker Neuson engine/equipment operator's manual. Wacker Neuson recommends that all receipts covering maintenance on the engine/equipment be retained, but Wacker Neuson cannot deny warranty coverage solely for the lack of receipts or for the failure to ensure the performance of all scheduled maintenance.

Normal maintenance, replacement, or repair of emission control devices and systems may be performed by any repair establishment or individual; however, warranty repairs must be performed by an authorized Wacker Neuson dealer/service center.

The engine/equipment must be presented to an authorized Wacker Neuson dealer/service center as soon as a problem exists. Contact Wacker Neuson Product Support Department (1-800-770-0957) or visit wackerneuson.com to find a dealer/service center in your area, or to answer questions regarding warranty rights and responsibilities.

How to Make a Claim

In the event that any emission-related part is found to be defective during the warranty period, you shall notify Wacker Neuson Product Support Department (1-800-770-0957, or technical.support@wackerneuson.com, or wackerneuson.com), and you will be advised of the appropriate dealer/service center where warranty repair can be performed. All repairs qualifying under this limited warranty must be performed by an authorized Wacker Neuson dealer/service center.

You must take your Wacker Neuson engine/equipment along with proof of original purchase date, at your expense, to the authorized Wacker Neuson dealer/service center during their normal business hours.

For owners located more than 100 miles from an authorized dealer/service center (excluding the states with high-altitude areas as identified in 40 CFR Part 1068, Appendix III), Wacker Neuson will pay for pre-approved shipping costs to and from an authorized Wacker Neuson dealer/service center.

Claims for repair or adjustment found to be caused solely by defects in material or workmanship will not be denied because the engine/equipment was not properly maintained and used.

The warranty repairs should be completed in a reasonable amount of time, not to exceed 30 days.

SAFETY MANUAL

FOR OPERATING AND MAINTENANCE PERSONNEL

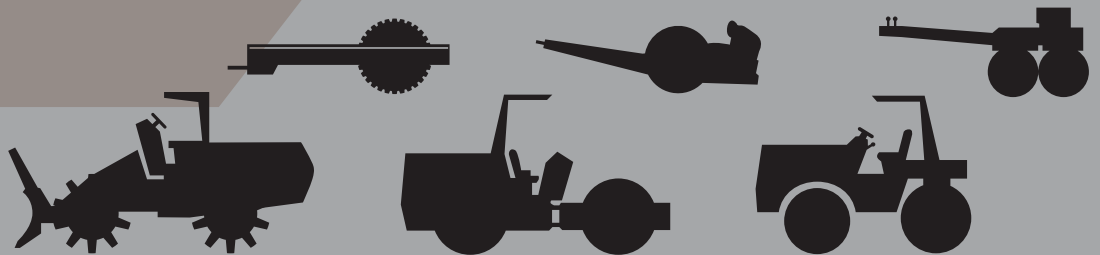

Table of Contents

Acknowledgment.....	2
Foreword	3
Safety Alerts.....	4
A Word to the User/Operator	5
Types of Roller Compactors.....	6
Follow a Safety Program.....	7
Prepare for Safe Operation.....	12
Start Safely.....	17
Operate Safely	20
Shut Down Safely	30
Perform Maintenance Safely	31
Final Word to the User	43

Acknowledgment

We wish to thank the members of the Association of Equipment Manufacturers for their invaluable contributions in preparing this Safety Manual.

NOTICE OF COPYRIGHT PROTECTION

Copyright 2014, by the Association of Equipment Manufacturers. All rights reserved. This work may not be reproduced or disseminated in whole or in part by any means without the prior written permission of the Association of Equipment Manufacturers.

Foreword

This safety manual is intended to point out some of the basic safety situations that may be encountered during the normal operation and maintenance of your machine and to instruct you in safety practices for dealing with these conditions. This manual is **NOT** a substitute for the manufacturer's operator's manual(s).

Additional precautions may be necessary, or some instructions may not apply, depending on equipment, attachments and conditions at the jobsite or in the service area. The manufacturer has no direct control over equipment application, operation, inspection or maintenance. Therefore, it is **YOUR** responsibility to use good safety practices in these areas.

The information provided in this manual supplements the specific information about your machine that is contained in the manufacturer's operator's manual(s). Other information that may affect the safe operation of your machine may be contained on safety signs or in insurance requirements, employer's safety and training programs, safety codes, local, state/provincial and federal laws, rules and regulations.

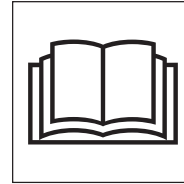

**Read and understand
manuals before
operating**

IMPORTANT! Before you operate this machine, make sure you have the manufacturer's manual(s) for this machine and all attachments. If the manufacturer's manuals are missing, obtain replacements from your employer, equipment dealer or directly from the manufacturer. Keep this safety manual and the manufacturer's manuals with the machine at all times. Read and understand all manuals.

Safety videos and other training resources are available from some manufacturers and dealers. Operators are encouraged to periodically review these resources.

Safety Alerts

Safety Alert Symbol

This Safety Alert Symbol means: "**ATTENTION! STAY ALERT! YOUR SAFETY IS INVOLVED!**"



The Safety Alert Symbol identifies important safety messages on equipment, safety signs, in manuals or elsewhere. When you see this symbol, be alert to the possibility of death or personal injury. Carefully read the message that follows and inform other operators. Follow instructions in the safety message.

Signal Words

Signal words are distinctive words that will typically be found on safety signs on the roller compactor and other jobsite equipment. These words may also be found in this manual and the manufacturer's manuals. These words are intended to alert the operator to a hazard and the degree of severity of the hazard.



DANGER indicates a hazardous situation that, if not avoided, will result in death or serious injury.



WARNING indicates a hazardous situation that, if not avoided, could result in death or serious injury.



CAUTION indicates a hazardous situation that, if not avoided, could result in minor or moderate injury.



NOTICE indicates a property damage message.

A Word to the User/Operator

It is **YOUR** responsibility to read and understand this safety manual and the manufacturer's manuals before operating this equipment. This safety manual takes you step by step through the working day.

Graphics have been provided to help you understand the text.

Hazard recognition and accident prevention depend upon you being alert, careful and properly trained in the inspection, operation, transport, maintenance and storage of this equipment.



Read and understand all safety signs – replace damaged signs

Remember that **YOU** are the key to safety. Good safety practices not only protect you but also protect the people around you. Study this manual and the manufacturer's manuals for the specific machine. Make them a working part of your safety program. Keep in mind that this safety manual is written only for the types of roller compactors covered.

After studying the manufacturer's manuals and this safety manual, please contact the equipment manufacturer with any remaining questions.

Practice all usual and customary safe working precautions and remember:
SAFE OPERATION IS UP TO YOU!
YOU CAN PREVENT DEATH OR SERIOUS INJURY CAUSED BY UNSAFE WORK PRACTICES!

Types of Roller Compactors

This safety manual covers many different types of roller compactors including: steel wheel rollers, vibratory rollers, rubber-tired rollers, segmented pad/sheepsfoot soil compactors and landfill compactors. These may be either ride-on, walk-behind, or towed rollers. They may be used for the compaction of asphalt, soil, landfill or other materials. Excluded from coverage are vibratory plates and hand rammers.

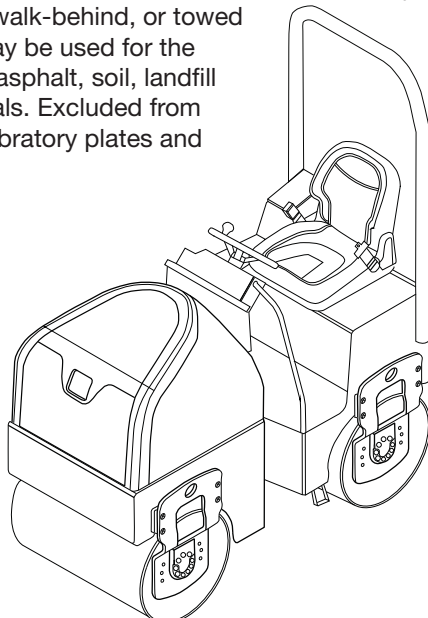

Ride-on

Regardless of which machine you operate, it is your responsibility to study and understand this safety manual, and to see that a copy remains with your machine. Manufacturers produce machines with many built-in safety features. Employers provide accident prevention programs. Yet, the ultimate responsibility to operate and maintain your machine with the skill, care and knowledge essential for safety is yours.

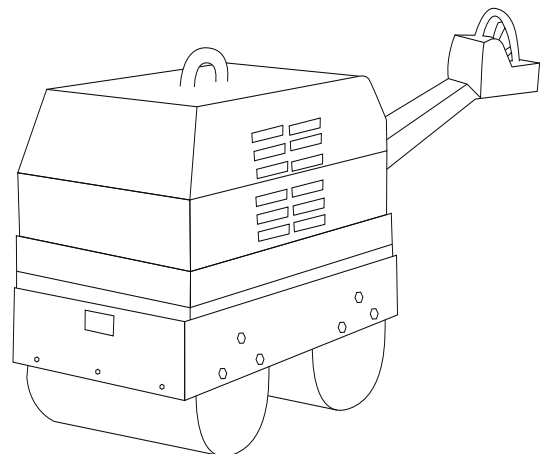

Walk-behind

Follow a Safety Program

For Safe Operation

You must be a qualified and authorized operator for safe operation of this machine. You must clearly understand the written instructions supplied by the manufacturer, be trained — including actual operation — and know the safety rules and regulations for the jobsite. It is a good safety practice to point out and explain safety signs and practices to others, and to make sure they understand the importance of following these instructions.



Never operate while impaired by alcohol or drugs

⚠ WARNING! Drugs and alcohol affect operator alertness and coordination, and the ability to safely operate the equipment. **Never operate the machine while impaired by use of alcohol or drugs. Never knowingly allow anyone to operate the machine when their alertness or coordination is impaired.**

An operator taking prescription or over-the-counter medication must consult a medical professional regarding any side effects of the medication that would hinder their ability to safely operate this equipment.

Be Alert!

Know where to get assistance. Keep emergency numbers for doctors, ambulance service, hospital and fire department near your telephone. Know how to use a first aid kit and fire extinguisher/fire suppression system; know their location and practice getting to them. Ensure they have been properly tested and maintained.

Let others know where you will be working, and what time you will be returning. In case of an emergency, you want others to know where to find you.

Be Aware!

Take advantage of training programs offered.

Know the proper response to a fire or chemical spill on your machine.

7

Follow a Safety Program

Be Careful!

Human error is the result of many factors: carelessness, fatigue, sensory overload, preoccupation, unfamiliarity with the machine or attachments, or drugs and alcohol, to name a few. You can avoid death or serious injury caused by these and other unsafe work practices. Be careful; never assume accidents cannot happen to you.

For your safety and the safety of others, act safely and encourage your fellow workers to act safely as well.

Protect Yourself

Wear all the personal protective clothing and Personal Protective Equipment (PPE) issued to you or called for by job conditions.

You may need:

- Hard hat.
- Safety shoes.
- Safety glasses, goggles or face shield.
- Heavy duty gloves.
- Hearing protection.
- Reflective clothing.
- Wet weather gear.
- Respirator or filter mask.

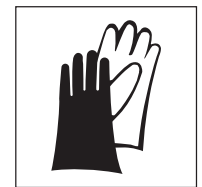
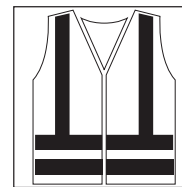
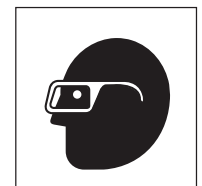
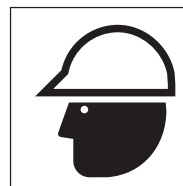

Wear whatever is needed to protect yourself — don't take chances.

⚠ WARNING! Avoid death or serious injury from entanglement. **Do not wear loose clothing or accessories that could catch on moving parts or controls.** Examples of items to avoid include flopping cuffs, dangling neckties and scarves, wallets attached to chains, jewelry and wrist watches.

Follow a Safety Program

Know the Rules

Most job sites have rules governing equipment use and maintenance. Before you start work at a new location, check with the supervisor or safety coordinator. Ask about the rules you will be expected to obey.

OSHA enforces federal laws within the United States that apply to the safe operation, application and maintenance of equipment on some jobsites. It is the employer's responsibility to comply with these laws. A federal representative may periodically inspect a jobsite to see that these laws are being followed.

There may be other local, state/provincial, federal laws or international organizations that regulate the use of this equipment, along with specific jobsite or employer rules. It is important that you know and comply with all applicable laws and rules, **including those requiring operator training and certification.**

These are some of the rules you must work by:

- Only qualified and authorized individuals may operate this equipment.
- Inspect your machine and attachments before each use as specified by the manufacturer and your employer.

- Know the capacity and operating characteristics of your equipment. Do not misuse it.
- Wear proper clothing and PPE. Check that others are also wearing appropriate clothing.
- All shields, guards, air filters, access panels and doors must be properly installed before each use.
- Know the rules regarding traffic at your jobsite. Know what all signs, flags, and markings mean. Know hand, flag, horn, whistle, siren, or bell signals, if used.
- Never modify or remove any part of the machine (except for service; then make sure the part is re-installed or replaced if defective or worn out).



Know and understand rules of operation



Understand jobsite signals

Follow a Safety Program

- **Never allow children to play near, ride on, or operate the equipment.**
- Keep bystanders well clear of the operation.
- Know the work area before you use the equipment. Be aware of possible hazards, including those overhead and underground.
- Only use attachments and parts that are approved by the manufacturer.
- Do not allow riders.
- Fasten seat belt or operator restraint before starting.
- Drive forward whenever possible.
- Always look in the direction of travel.
- Check correct mirror settings, if available.
- Look before backing up.
- Never leave the operator's seat without stopping the engine and removing the ignition key, if equipped. (See page 30, **Safe Shutdown.**)
- Use three-point contact (handholds and steps) and face the equipment when mounting or dismounting. (See page 17, **Mount and Dismount Properly.**)



Fasten seat belt or operator restraint

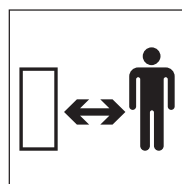

Keep bystanders away

Follow a Safety Program

Know the Equipment

Read and understand the DANGER, WARNING, CAUTION and NOTICE safety labels and other informational signs on the machine and the attachments, and in the manufacturer's operating manuals. Ask your supervisor or dealer to explain any information you do not understand. Failure to obey safety instructions could result in death or serious injury.

Know the following about your equipment:

- Function, purpose and use of all controls.
- Correct operation speeds.
- Slope and uneven terrain capabilities and proper operation under all conditions.
- Braking and steering characteristics.
- Turning radius and clearances.
- How to quickly stop equipment in an emergency.
- Rated operating capacity.

Keep in mind that rain, snow, ice, loose gravel, soft ground, slopes, and other site conditions can affect your machine's operating capabilities. Make sure you are thoroughly familiar with your machine's stability, braking, traction, and other handling characteristics under any conditions you are likely to encounter.

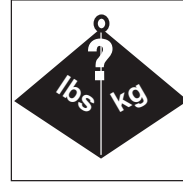

Know machine capacity and operating characteristics

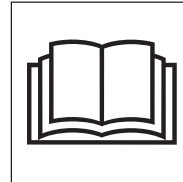

Read and understand manuals before operating

11

Prepare for Safe Operation

Check and Use All Available Safety Devices

To protect you and others around you, your machine may be equipped with the safety equipment listed below. Additional equipment may be required or some items may not apply, depending on attachments used, jobsite conditions or applicable jobsite rules. Check that each required item is securely in place and in operating condition:

- Falling Object Protective Structure (FOPS).
- Rollover Protective Structure (ROPS).
- Safety Guards.
- Seat Belt.
- Operator seat/restraint bar(s)/interlock control system.
- Cab side-screens or windows.
- Special enclosures or accessories required for specific applications or jobsite conditions.
- Alternate exit (window).
- Grab handles.
- Guard Rails.
- Articulated joint locks
- Lights.
- Mirrors.

- Anti-skid tread/steps.
- Safety signs.
- Horn.
- Guards.
- Back-up alarm.
- Emergency stop control.
- Fire extinguisher.
- First aid kit.
- Rotating beacon.
- Windshield wiper/defroster.

Use them! Never remove or disconnect any safety device. Replace any damaged, missing, or non-functional safety devices before resuming machine operation.

⚠ WARNING! Never remove or modify a ROPS or FOPS. Serious injury or death could result.



Fasten your seat belt

Prepare for Safe Operation

Check the Machine

Before beginning your work day, inspect the machine and have all systems in good operational condition.

- Perform daily and periodic service procedures as instructed by the equipment manufacturer.
- Check for broken, missing, loose, or damaged parts. Make necessary repairs.
- Check that all drum mounting bushes are pliable and free from damage.
- Check the water sprinkler system. Open the valve and make sure water flows through every hole in each spray bar.
- Check the tires for cuts, missing lugs, bulges, and correct pressure.
- Keep the steps and handholds clean and free of grease, oil, dirt, snow or ice.
- Check the parking brake for proper operation.
- Check condition and operation of any attachments.
- Ensure shielding is properly installed and in good condition. Repair or replace if damaged or missing.
- Ensure work lights (if equipped) are kept clean. Check that all lights work properly.
- Ensure the horn and back-up alarm (if equipped) are operating correctly. Repair or replace if damaged.

- Ensure any Slow Moving Vehicle (SMV) signs, reflectors and warning lights are in good condition and can be clearly seen. Repair or replace if damaged.
- Ensure all tools or loose objects are removed or securely fastened while operating the machine.
- Check for damaged or leaky hydraulic systems. Repair or adjust as needed.



**Inspect
the machine before
each work shift**

Hydraulic Fluid Injection Hazard

⚠ WARNING! Accidental injection of high-pressure oil into the hands or body is dangerous and could result in death or serious injury. **Use caution when checking hydraulic leaks as pressurized hydraulic fluid has enough force to penetrate skin, causing serious personal injury.**

13

Prepare for Safe Operation

If a leak is discovered:

- Ensure engine is turned off; relieve pressure in hydraulic circuit.
- Wear proper hand and eye protection.
- Visually examine the hydraulic hose or fluid lines in the vicinity of the leak for breaks or cracks. **Do not** use your hand to check for leaks.
- Repair or replace hydraulic lines per manufacturer's recommendation.

Fluid injection injuries are not always obvious. Victims have reported such injuries feel like a bee sting or splinter under the skin. If you suspect you have a fluid injection injury, do not take chances. Seek proper medical care immediately. If any fluid is injected into the skin, it must be surgically removed within a few hours by a doctor familiar with this type of injury.

Check the Cooling System

When checking the cooling system, make sure the engine is turned off and is cool. Remove the key to prevent fans from unexpectedly starting. Ensure the coolers and engine compartment are clean and free from debris, which could ignite and cause a fire.

If the machine is air-cooled, be sure the cooling unit has an unobstructed air flow. If it is liquid-cooled, check coolant level (at overflow tank, if provided).

⚠ WARNING! Allow the radiator to cool before checking the level. Hot radiator fluids could escape as steam and burn you. (See page 36, **Engine Coolant Hazards.**)

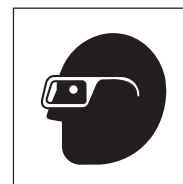

**Wear
eye protection**



**High pressure
fluid can inject
into the body**

Prepare for Safe Operation

Clean Up

Clean windows, lights, mirrors, and safety signs.

Make sure the operator's area, steering levers, pedals, joysticks, steps, and grab handles are clean. Oil, grease, snow, ice, mud, or debris in these areas could cause you to slip and fall, or lose control of the machine. Clean your boots of excess mud before entering the machine.

Remove all personal items or other objects from the operator's area. Secure these items in a toolbox or remove them from the machine.

Use Caution When Fueling

⚠ WARNING! Avoid injury from fire or explosion. **Never fill the fuel tank in poorly ventilated areas, with the engine running, while smoking, or when near an open flame.**

Never overfill the tank or spill fuel. If fuel is spilled, clean it up immediately.

Be sure to use the correct type and grade of fuel.

Ground the fuel funnel or nozzle against the filler neck to prevent sparks that could ignite fuel vapors. Be sure to replace the fuel fill cap (if equipped) when you are done.

Ultra-Low Sulfur Diesel (ULSD) Fuel Hazard

Avoid Static Electricity Risk When Fueling

⚠ WARNING! Ultra-Low Sulfur Diesel (ULSD) poses a greater static ignition hazard than earlier diesel formulations with higher sulfur content. Avoid death or serious injury from fire or explosion; **consult with your fuel or fuel system supplier to ensure the delivery system is in compliance with fueling standards for proper grounding and bonding practices.**

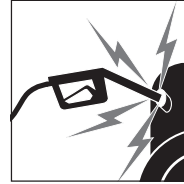

Static discharge during fueling can cause explosion

15

Prepare for Safe Operation

Know the Working Area

Learn as much about your working area as possible.

Check at Ground or Floor Level

Inspect the surface over which you will travel. Look for holes, drop-offs and obstacles. Look for rough spots or hidden obstacles on surfaces which could cause a collision or loss of control. Look for weak spots on docks, ramps or floors. Look for oil spills, wet spots, and slippery surfaces. Look for soft soil, deep mud or standing water. Watch for anything that might make you lose control or cause the machine to roll over.

When operating inside a building, make certain you are within weight limitations of floors and ramps. Be aware of overhead clearances, doorways, aisles, etc. Plan travel routes ahead of time, in order to make sure you can see and protect bystanders. Pick up debris that can puncture tires.

Be observant of other workers, bystanders, and other machines in the area.

Remember, the danger of sliding and/or tipping on steep slopes is always present, regardless of how heavy or stable your machine may appear to be. Always use seat belts if a ROPS is equipped.

Check Overhead

Check the clearances of doorways, canopies, and overheads. Know exactly how much clearance you have under power and telephone cables.

⚠ DANGER! Contact with energized power lines will cause serious injury or death. **Never approach overhead power lines with any part of your machine unless all local, state/provincial and national (OSHA) required safety precautions have been taken.** Always use extreme caution around power lines.

Know your margin of safety. If possible, have power to lines disconnected. If not possible, request a signal person for guidance.

⚠ DANGER! Electrocutation will result from touching or being near a machine that is in contact with, or near, an electrical source. **Stay away from any machine in contact with electrical wires until you are told it is safe to approach.**

Start Safely

Mount and Dismount Properly

Always use three-point contact when mounting or dismounting the machine. Three-point contact means one hand and two feet, or two hands and one foot, in contact with the machine at all times.

Never mount or dismount while carrying tools or objects that prevent three-point contact. Put parts or tools down. Maintain proper contact, climb or dismount, and then pick up the object.

Face the machine when you enter or leave the machine.

Clean shoes and wipe hands. Clean steps and handholds of chemical residue, snow, ice, mud or oil.

During mounting and dismounting:

- Use handholds and step plates.
- Never use steering wheels, joysticks or controls as handholds.
- Never jump on or off the machine.
- Never mount or dismount from a moving machine.

Warn Personnel Before Starting

Before starting, walk completely around the machine.

Make sure no one is under the machine, on it, or close to it. Let others know you are starting up and don't start until everyone is completely clear of the machine. As the equipment operator, you are responsible for the safe use of the machine, so always make sure you have communicated your work plans to others on the site.



Use three points of contact when mounting or dismounting



Avoid falls, clean up slippery areas

17

Start Safely

Starting the Engine

⚠ WARNING! Start the engine from the operator's seat only. **Never attempt to start the engine by shorting across starter terminals.** The machine may move unexpectedly, which could cause serious injury or death to anyone in its path.

Before starting, walk completely around compactor. Know the exact starting procedure for your machine. See the manufacturer's operating manual(s) for starting.

- Sit in the operator's seat and adjust the seat so you can operate all the controls properly.
- Fasten the seat belt/operator restraint.
- Familiarize yourself with warning devices, gauges and operating controls.
- Make sure controls are in the neutral/locked position.
- Clear the area of all persons.
- Start the engine following the instructions in the manufacturer's operating manual(s).
- If necessary to run the engine or operate the machine within an enclosed area, be sure there is adequate ventilation.

⚠ WARNING! Exhaust fumes can kill. **Do not breathe exhaust fumes!**

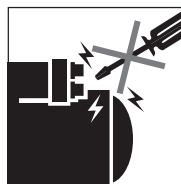

Never start engine by shorting across starter terminals

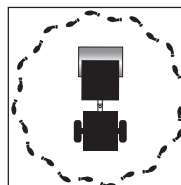

Before starting, walk completely around compactor

Starting Aids

Ether/cold start fluid is **HIGHLY FLAMMABLE**. Before using it, always read the instructions on the ether/cold start fluid container and the instructions in the manufacturer's operating manual(s).

⚠ WARNING! Avoid injury from explosion or fire. If the engine is equipped with a glow plug pre-heater or other intake manifold type pre-heater, follow manufacturer's instructions before using ether/cold start fluid.

If you have trouble starting the engine and need to use jumper cables, follow the instructions in manufacturer's

Start Safely

operating manual(s). **Jump-starting is a two-person operation.** The operator must be in the operator's seat when jump-starting so the machine will be under control when the engine starts. Wear appropriate PPE before attempting to jump-start your machine.

⚠ WARNING! A battery explosion or a run-away machine could result from improper jump-starting procedures. (See page 38, **Battery Hazards.**)

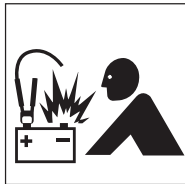

To avoid explosion,
follow proper jump-
starting procedures

After Starting Engine

Observe gauges, instruments, and warning lights to assure that they are functioning and their readings are within the operating range.

Run an Operating Check

Do not use a machine that is not in proper operating condition. It is your responsibility to check the condition of all systems and to run the check in a safe area.

Test Controls

Roller compactors come equipped with various control configurations, patterns and operating modes, each with their own handling characteristics. Some have selectable or configurable controls, to suit personal preferences or specific applications. Make sure that you know which control pattern you have selected and that you understand how the machine will handle when using that control pattern.

Make sure the machine is operating properly by doing the following:

- With the control levers or joysticks in neutral, test engine speed control.
- Operate each pedal, lever or joystick to make sure all functions are correct.
- Operate the travel control lever(s) or joysticks to ensure correct operation in forward and reverse. Test steering to the right and to the left, while moving slowly in a clear, safe area.

⚠ WARNING! Before operating the machine under working conditions, **be certain you can control both the speed and direction of the machine.** Any loss of control could result in death or serious injury.

19

Operate Safely

Masked Visibility Areas

Machines have areas where the operator's visibility of the job site can be affected by the machine itself. ROPS posts, attachments, a drum, even items in the cab, could limit your view of the surrounding area and possibly mask hazards or people around you. These masked visibility areas vary from machine to machine, and it is very important you be aware of these areas before operating your machine.

Follow these safety precautions to reduce the hazards posed by masked visibility areas:

- Look around the machine before operating. Objects near the machine and close to the ground can be difficult to see from the cab.
- Always look in the direction of travel, including reverse. A back-up alarm is no substitute for looking behind you when operating the machine in reverse.
- Keep bystanders away, even if your machine is equipped with a back-up alarm.

Remember These Rules

Never allow untrained, unqualified, or unauthorized personnel to operate your machine.

Never allow other personnel to ride on your machine unless appropriate seating is provided, and then, only if authorized to do so.

Never abuse your machine. Misuse or abuse can cause an accident.

Articulated Machines

Never enter or place any part of your body in the "hitch area" or "pinch areas" of an articulated machine while the engine is running, or when there is any chance another person could start the machine.

If available, use the articulated joint lock during maintenance work, transportation, etc.

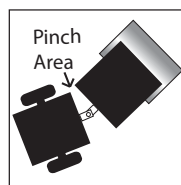

Keep body parts away
from pinch area

Operate Safely

Work on Slopes Safely

When working on slopes, avoid side-hill travel whenever possible. It is generally safer to operate up and down the slope. Remember the danger of sliding and/or tipping on steep slopes is always present, regardless of how heavy or stable your machine may appear to be.

Always use seat belts if your machine is equipped with a ROPS. If equipped, make sure foldable ROPS is upright. Keep your hands and feet inside the cab at all times.

When climbing or descending steep grades, select the proper gear before starting on the slope, to assure adequate power or engine breaking.

If your machine has a gear shift, select a low gear. If your machine has a hydrostatic drive, the speed control should be in the slow travel position, close to neutral, not in the fully displaced position.

On machines that have a gear shift and a hydrostatic control, both controls must be in their slow travel position.

Always be sure that manually operated gear type transmissions are fully engaged before starting onto a grade. Do not attempt to change the gear selection while traveling on a grade. See the manufacturer's manual for specific instructions.

Watch Out for Hazardous Working Conditions

Be alert for hazards. Know where you are at all times. Watch for overhead obstacles. Look up as well as down.

Avoid operating your machine too close to an overhang, deep ditch or hole. If your machine inadvertently gets close to a tipping condition or drop-off, STOP and get off the machine after applying the parking brake. Plan your moves carefully before proceeding. Reversal is often the best move.

⚠ WARNING! Never operate the machine close to the edge of an overhang or gully. The edges could collapse or a slide could occur causing serious injury or death.

Stay Alert! Rough Terrain Can be Hazardous!

Be alert to obstacles and excessively rough terrain. Back away from them and go around.

Always travel slowly over rough terrain and hillsides. Maintain a speed consistent with the working conditions.

21

Operate Safely

Follow Safe Operating Practices

Make these safe practices part of your daily routine:

- Keep your seat belt/operator restraint fastened.
- Never leave the operator's seat without having the unit come to a complete stop and applying the breaks.
- Operate the controls smoothly — don't jerk the steering levers or joysticks.
- Avoid sudden stops, starts or turns.
- Use care and good judgment.
- Never attempt to operate the controls unless properly seated in the cab.
- To shut down the machine, stop the engine and remove the ignition key, if equipped. (See page 30, **Safe Shutdown.**)

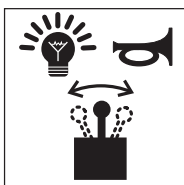

Operate
instruments
and controls
smoothly

⚠ WARNING! Avoid Serious injury or death! **Keep your entire body inside the operator's cab while operating the machine.** Never work with your head, arms, feet or legs beyond the operator's compartment.

Traveling on Jobsite

Take it slow and easy when traveling through congested areas. Traffic courtesy pays off.

Give the right-of-way to loaded machines. Maintain a safe distance from other machines. Pass cautiously.

Don't obstruct your vision when traveling or working. (See page 20, **Masked Visibility Areas.**) Operate at speeds slow enough so you have complete control at all times. If possible, avoid travel over rough, slippery or uneven terrain, and on hillsides.

Travel Safely

When roading the machine, know your approximate stopping distance at any given speed.

Travel at controlled speeds, especially around corners.

Look in all directions before reversing your direction of travel.

Never coast in neutral.

Operate Safely

Avoid steep slopes or unstable surfaces. If you must drive on a slope, travel at an appropriate speed and with extreme caution. Do not drive across an excessively steep slope under any circumstances. Travel straight up and down the slope. Before operating on slopes, check the surface conditions for adequate traction. Loss of traction can cause the machine to slide and tip.

⚠ WARNING! Avoid death or serious injury. **Travel up and down slopes with the heavy end of the machine pointed uphill.**

Check machine manufacturer's recommendations.

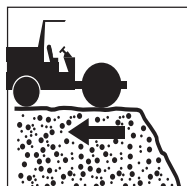

Operate perpendicular to banks – stay back from the edge

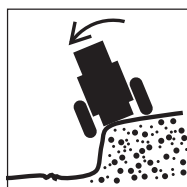

Use caution – stay safely away from bank or excavation edge

Rules of the Road

When traveling on public roads or streets, obey all traffic regulations applicable to machine use and classification.

Make sure lights and warning signs are in place and visible. Make sure a SMV emblem is installed and visible to any vehicle approaching from the rear.

Find out if you must use an escort vehicle. Approach intersections with caution; observe speed and traffic control signs. Avoid panic stops and sharp turns.

Like any responsible operator, be considerate of other drivers. If traffic backs up behind you, it is a good idea to pull over periodically and allow traffic to pass when it is safe to do so.

Stop at all railroad crossings and look both ways before proceeding. Never park in traffic areas. If it is necessary to stop at night, pull off the road and set up flares or reflectors. When driving at night, use appropriate lights.

Watch Out for Obstacles

Adjust your speed to conditions. Avoid crossing ditches, curbs or exposed railroad tracks. If obstacles are unavoidable, reduce speed and cross at an angle.

23

Operate Safely

Keep your machine under control. Keep speed to a minimum when visibility is poor.

Before entering underpasses, tunnels or bunkers, check for oncoming traffic or obstructions.



Obey traffic regulations

Work at Night Safely

Night operations require additional precautions to stay safe. Pay close attention and stay alert. Others passing through the work site may not be aware of hazards.

Plan the job, communicate the plan and inspect the work area during daylight. Mark obstacles ahead of time with reflective material.

Wear appropriate reflective apparel at all times – for operators and crew on night operations.

Ensure visibility of gauges and controls.

Ensure adequate lighting to illuminate work zone in compliance with state and local regulations and requirements.

Ensure adequate hazard lights (strobe or flashing/rotating lights) in compliance with state and local regulations and requirements.

Utilize direct line of sight, not mirrors, when working at night. Use spotters when direct line of sight is not possible. Lights can reflect in mirrors, causing a hazard to be unseen, or a masked visibility area.

Lack of natural light will impact visibility and may increase the risk of being backed over by vehicles or equipment.

Adjust work lights to minimize glare for traffic and workers.

Know where the other workers are at all times. Tell others where you are going.

Beware of fatigue. Check on crew members.

Stay in assigned work zones.

Enter and exit machine on side away from traffic, if possible.

Operate Safely

Exhaust Fumes in a Closed Space Can Kill

Vent exhaust and assure a flow of fresh air when an internal combustion engine is used in a closed space.

⚠ WARNING! Exhaust fumes can kill. **Do not breath exhaust fumes from any kind of engine.**

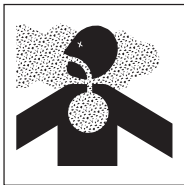

Operating in Flammable/Explosive Atmospheres

⚠ WARNING! A roller compactor cannot be operated in flammable or explosive atmospheres.

Use in explosive atmospheres can result in fires and/or explosions which could cause serious injury or death.



Loading and Unloading Safely

Always wear your seat belt/operator restraint when loading or unloading your machine from a transport device, such as a flatbed truck.

When transporting a compactor, follow the manufacturer's recommended loading and unloading procedures.

Extreme care should be exercised when loading or unloading a walk-behind roller. It is generally best to stand behind and off to one side rather than directly behind a machine moving up or down a ramp.

Several precautions are applicable to all machines:

- Never load or unload a machine by yourself.
- Keep bystanders away.
- Load and unload on a level surface.
- Maintain proper visibility by loading or unloading in well-lit areas, and away from other vehicles, equipment or buildings.
- Block transport vehicle with wheel chocks so it cannot move.
- Ensure trailer bed and ramps are in good condition.
- Use ramps of adequate size and strength, with a low angle and proper height.

25

Operate Safely

- Rear of trailer must be blocked or supported.
- Keep trailer bed and ramps free of clay, oil, ice, snow, and other materials which could become slippery.
- Chain and block the machine securely for transport. Use tie-down points as marked on the machine by the manufacturer. Follow the manufacturer's instructions in the operator's manual for tying down.
- Cover or remove rear-facing SMV sign on the roller compactor, if equipped, to avoid confusing drivers following the transport vehicle.
- Unload the machine by driving off in the opposite direction; do not turn the machine around.

Transporting Safety Tips

General

When towing a machine on a trailer, or a machine equipped with "portability or transport wheels," always use a hauling vehicle of sufficient weight, horsepower and braking capacity to maintain proper control.

Never attempt to tow a trailer or machine if the hitching devices are of insufficient or questionable capacity, improperly matched in size or shape, or positioned at improper heights.

When towing a machine equipped with portability or transport wheels, always follow the manufacturer's towing instructions.

Before Towing

When connecting a trailer to a hauling vehicle, block under the trailer's tongue before attempting to make the connection. Never attempt to lift heavy tongues or move heavy trailers by hand. Never get any part of your body under the tongues when hitching or unhitching.

Make sure the hitch pin is of the proper size and securely locked in place before towing.

If the roller is designed to hang from the tailgate of a vehicle when being transported, be certain the hook brackets meet the roller manufacturer's specifications.

Use tow bars between the hauling vehicle and trailer or towed machine. Be sure the chains are properly and securely connected at both ends. Cross the chains under the tongues when connecting to the hauling vehicle.

Make sure electrical and other connections between the hauling vehicle and trailer or towed machine are properly and securely made. After connecting, check the lights for proper operation. If the towed trailer or

Operate Safely

machine is equipped with brakes operable from the hauling vehicle, check to make sure they are operating properly.

Always be sure the portability or transport wheels, on machines so equipped, are locked in the lowered position.

Check all tires for proper pressure, excessive or abnormal wear, and potentially dangerous cuts, bruises or bulges. Have any problems corrected before proceeding.

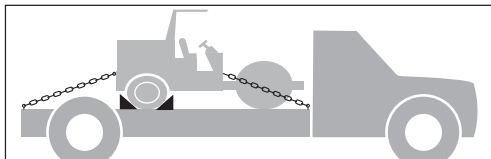

Chain and block compactor securely for transport

Towing

Use care when towing a trailer or machine when:

- Maneuvering in tight places
- Backing (visibility is reduced, and jackknifing must be avoided)
- Towing on steep grades.

Know and obey all local, state and federal laws and regulations.

Do not travel at speeds above those recommended by the manufacturer.

Do not allow anyone to ride on a trailer or towed machine.

When necessary to disconnect and park a trailer or towed machine, select a location that is level and, if possible, where children are unlikely to be present. Before disconnecting a trailer, block the front AND rear of the wheels and block under the tongues.

27

Operate Safely

Walk-Behind Rollers

Start-up

Only operate a walk-behind roller if you are thoroughly familiar with the manufacturer's operating instructions. If you have any questions or uncertainty, consult the manufacturer or dealer before attempting to operate it.

Always follow the manufacturer's instructions for starting the engine. All controls must be in the correct position before attempting to start the engine

Starting fluid is not recommended when hand starting an engine, because the engine may kick back, causing injury.

Operation

When operating a walk-behind roller, exercise extreme care to avoid having your feet or clothing caught under the dolly wheels or roller. When possible, stand behind and off to one side of the machine, rather than directly behind it.

Particular care must be exercised when operating near obstructions and on slippery surfaces, grades and side slopes. Wear slip-resistant safety shoes or boots.

Do not ride on a walk-behind roller unless it is designed to accommodate riders and an appropriate seat is provided.

Do not attempt to shift on a grade if the roller has a mechanical transmission.

Do not operate a walk-behind roller in unshored trenches or near steep, unsupported banks. The vibrations could cause a cave-in.

Uneven grades can cause the handle to raise or lower unexpectedly, striking the unwary operator.

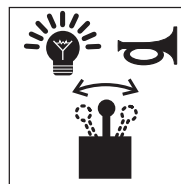

Set all controls to correct position before starting the engine

Operate Safely

Towed Rollers

Most general safety precautions covered earlier in this manual are also applicable to towed roller operation. There are many precautions specific to towed rollers that must be taken. Study your manufacturer's manual for instructions on your specific towed roller. Consult the manufacturer or dealer with any concerns.

Use a tow tractor of sufficient weight, drawbar horsepower and braking capacity to properly control the towed roller. Proper weight balance and distribution is also essential.

Block under the tongues of the towed roller before attempting to connect it to the towing vehicles or machine. Do not attempt to lift heavy tongues or move towed rollers by hand. Do not get any part of your body under the tongues when hitching or unhitching.

Make sure the hitch pin is of the proper size, and is securely locked in place before towing. If safety chains are provided, make sure they are properly and securely connected at both ends. Cross the chains under the tongues when connecting to the towing vehicle. Make sure all electrical or hydraulic connections are made properly and securely.

Landfill Compactors

Operators of landfill compactors should carefully handle materials that could be picked up and thrown by the wheels, become lodged in the machine, or that are highly flammable.

Frequent checks should be made for wire, cable or other material wound around the axle members. Remove them immediately.

Travel with the blade as low as possible.

Maintain good operator visibility. Keep all mesh and windows free of accumulated materials.

When parking the machine, always lower the blade.

29

Shut Down Safely

Select a Proper Parking Site

Park in an off the road area, out of traffic, or as instructed. If necessary to park in a traffic lane, use the appropriate flags, barriers, flares, lights and warning signals. Provide advance warning signals in the traffic lane to warn approaching traffic.

Park on level ground whenever possible. When that's not possible, position the machine at right angles to the slope. Make sure the machine is on a firm footing, and that there is no danger of sliding. Do not leave your machine until you are sure it is safely blocked in both directions and parking brakes are firmly applied.

⚠ WARNING! Avoid death or serious injury. **Never leave the compactor unattended with the engine running.**

Safe Shutdown

Know the proper shutdown procedure for your machine. As with the starting procedure, this varies with the type and model of machine.

If equipped, always lower the dozer blade when parking.

Follow the manufacturer's operation manual for your machine. Remove the key(s) to prevent unauthorized starting and movement, and position and lock any antivandalism devices.

Dismount Properly

Make sure your machine is fully stopped and shut off before dismounting. When you leave the compactor, always maintain three-point contact with the steps and grab handles. Face the compactor as you dismount. Never jump off a machine.

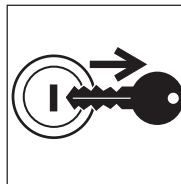

Shut engine off,
remove key



Use three points
of contact when
mounting or
dismounting

Perform Maintenance Safely

Know What You're Doing

Maintenance on this type of machine is not for inexperienced or untrained personnel. It can be hazardous unless performed properly. Be sure you have the necessary skill, information, correct tools and proper equipment to do the job safely.

Be sure to maintain the equipment according to the manufacturer's instructions. Regularly check the operation of the protective and safety devices.

Do not perform any work on a machine unless you are authorized and qualified to do so.

If you have been authorized to perform maintenance, **read the manufacturer's operating and service manuals.** Study the instructions. Check the lubrication charts and examine all the instruction messages on the machine.

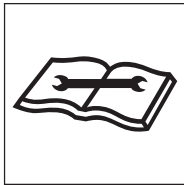

Maintain equipment

Protect Yourself

Wear all the personal protective clothing and PPE issued to you or called for by job conditions or your supervisor.

You may need:

- Hard hat.
- Safety shoes.
- Safety glasses, goggles or face shield.
- Heavy duty gloves.
- Hearing protection.
- Reflective clothing.
- Wet weather gear.
- Respirator or filter mask.

Wear whatever is needed to protect yourself. Do not take chances.

Perform Maintenance Safely

⚠ WARNING! Avoid death or serious injury from entanglement. **Do not wear loose clothing or accessories. Stay away from all rotating components when the engine is running.** Contact, wrapping or entanglement with rotating or moving parts could result in death or serious injury.

Wear a rubber apron and rubber gloves when working with corrosives. Wear gloves and safety shoes when handling wooden blocks or sharp-edged metal.

Always use safety glasses, goggles or a face shield. They provide eye protection from fluids under pressure, during grinding and while servicing batteries. Protection is also needed from flying debris, liquids and loose material produced by equipment, tools and pressurized air/water.

Wear a face shield and follow manufacturer's instructions when you disassemble spring-loaded components or work with battery acids. Keep pockets free of all objects that could fall out and drop into machinery.

Handle tools and heavy parts sensibly, with regard for the safety of yourself and others. Lower items; don't drop them.



Avoid rotating parts

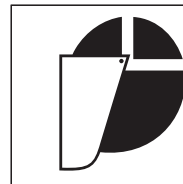

Wear eye protection



Do not loosen radiator cap until cool

Perform Maintenance Safely

Prepare the Work Area

- Position the machine on a level area out of the way of other working equipment.
- Make sure there is adequate light, ventilation and clearance.
- Remove oil, grease or water and dry slippery surfaces.
- Clean around the area to be serviced to minimize contamination.



Avoid falls, clean slippery surfaces

Prepare the Machine

Stored energy sources (electrical, mechanical, hydraulic, pneumatic, chemical, thermal, etc.) must be controlled or reduced to a practical minimum before performing any maintenance, repair, or service procedures.

Safety practices to prevent potential injuries from energy-releasing sources include:

- Place controls in NEUTRAL or LOCKED position before shutting off engine.
- Set parking brake or block wheels.
- Allow all moving parts to stop.
- Shut off engine.
- Relieve hydraulic system pressure by moving controls several times in all directions or per manufacturer's instructions.

- Lock out the unit according to the manufacturer's manual.
- Attach a "DO NOT OPERATE" warning tag to the control levers.
- Lock ignition, remove key (if equipped) and take it with you.
- Look and listen for evidence of moving parts before dismounting.
- Shut off master electrical switch (if equipped).
- Disable the battery switch (if equipped).
- Securely support or block up machine or other components with approved locking devices before working underneath them.
- Relieve pressure before disconnecting or disassembling any pressurized system.
- Block or relieve spring pressure before disassembling any spring-loaded mechanism.
- Avoid flames, sparks, or smoking near any fuel, hydraulic fluid or other flammable material such as spraying debris.

33

Perform Maintenance Safely

⚠ WARNING! Unsupported raised machines or other equipment may drop unexpectedly. **Never go under equipment when raised unless supported by an approved support device(s).** Death or serious crushing injury could result from falling equipment.

Remove only guards or covers that provide access to the area being serviced. Replace all broken or missing guards and covers when work is complete.

⚠ WARNING! Avoid injury or death. **Never work on machinery with the engine running unless instructed by the manufacturer's manuals for specific service.**



Use a "DO NOT OPERATE" tag

Common Maintenance Safety Practices

Use Proper Ventilation

If it is necessary to run an engine in an enclosed area, remove the exhaust fumes from the area with an exhaust pipe extension.

If you do not have an exhaust pipe extension, make sure you open doors and windows to get plenty of outside air into the area.



Ventilate work area

⚠ WARNING! Exhaust fumes contain carbon monoxide which could be deadly if inhaled. **Never operate any type of engine without proper ventilation.** EXHAUST FUMES CAN KILL.

Perform Maintenance Safely

Use Jacks and Hoists Carefully

Safety stands or blocks must be located on a rigid part of the machine. Do not position stands under axles or wheel supports that may rotate. Refer to manufacturer's manual.

⚠ WARNING! Prevent crushing injury. **Never use concrete blocks for supports. They could collapse under even light loads.**

If you must work beneath raised equipment, always use wood blocks, jack-stands or other rigid and stable supports. When using jacks or hoists, always be sure they are adequately supported.

Make sure the hoists or jacks you use are in good repair. Never use jacks with cracked, bent, or twisted parts. Never use frayed, twisted or pinched cables. Never use bent or distorted hooks.



Avoid crushing, use proper support for raised equipment.

Fuel Hazards

⚠ WARNING! Avoid serious injury or death. **Always use approved fuel containers and/or fuel dispensing equipment to reduce the risk of explosion or fire.**



No smoking and no open flames

Always observe these practices to reduce the possibility of a serious accident:

- Shut off engine and ignition during refueling.
- Always ground the fuel nozzle against the filler neck to avoid sparks.
- Keep sparks and open flames away from fuel.
- Do not smoke while refueling or when handling fuel containers.
- Do not cut or weld on or near fuel lines, tanks or containers.
- Do not overfill the tank or spill fuel. Clean up spilled fuel immediately.

35

Perform Maintenance Safely

Ultra-Low Sulfur Diesel (ULSD) Hazard

⚠ WARNING! Ultra-Low Sulfur Diesel (ULSD) poses a greater static ignition hazard than earlier diesel formulations. Avoid death or serious injury from fire or explosion; **consult with your fuel or fuel system supplier to ensure the delivery system is in compliance with fueling standards for proper grounding and bonding practices.**

Engine Coolant Hazards

⚠ WARNING! Avoid serious injury or death. Liquid cooling systems build up pressure as the engine gets hot, so **use extreme caution before removing the radiator cap.**

- Stop the engine and wait for the system to cool.
- Wear protective clothing and safety glasses.
- Turn the radiator cap slowly to the first stop to allow the pressure to escape before removing completely.



Remove radiator cap slowly

Hydraulic System Hazards

Be sure to follow manufacturer's instructions for relieving fluid pressure before performing any maintenance. The hydraulic system is pressurized whenever the engine is on and may hold pressure even after the engine is shut off. Cycle hydraulic controls, including auxiliary hydraulic control (if equipped), after the engine is shut off.



Check for leaks and inspect hoses

During inspection of the hydraulic system:

- Wait for fluid to cool before disconnecting the lines. Hot hydraulic fluid can cause SEVERE BURNS.
- Wear appropriate eye protection. Hydraulic fluid can cause permanent eye injury.
- When venting or filling the hydraulic system, loosen the filler cap slowly and remove it gradually.
- **Never** reset any relief valve in the hydraulic system to a pressure higher than recommended by the manufacturer.

Perform Maintenance Safely

Hydraulic Fluid Injection Hazard



High pressure fluid
can inject into
the body

⚠ WARNING! Accidental injection of high-pressure oil into the hands or body is dangerous and could result in death or serious injury. **Use caution when checking hydraulic leaks as pressurized hydraulic fluid has enough force to penetrate skin, causing serious personal injury.**

If you discover a leak:

- Ensure engine is turned off; relieve pressure in hydraulic circuit.
- Wear proper hand and eye protection.
- Visually examine the hydraulic hoses or fluid lines in the vicinity of the leak for breaks or cracks. **Do not** use your hand to check for leaks.
- Repair or replace hydraulic lines according to the manufacturer's recommendations.

Fluid injection injuries are not always obvious. Victims have reported such injuries feel like a bee sting or splinter under the skin. If you suspect you have a fluid injection injury, do not take chances. Seek proper medical care immediately. If any fluid is injected into the skin, it must be surgically removed within a few hours by a doctor familiar with this type of injury.

Diesel Particulate Filter Hazard

You may need to run an active regeneration on some machines with a diesel particulate filter (DPF). Running an active regeneration to clean a DPF can create extremely high temperatures. Consult your operator's manual for the proper procedure for running an active regeneration.

⚠ WARNING! Extremely high temperatures can cause a fire or explosion, so **do not run an active regeneration in an explosive or flammable atmosphere.**

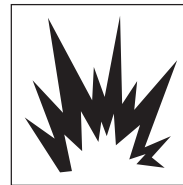

Do not operate in
explosive/flammable
atmosphere

37

Perform Maintenance Safely

Electrical System Hazards

Light Bulbs and Illumination

Some machines are equipped with High-Intensity Discharge (HID) Xenon light bulbs which operate at very high voltage. Do not begin installation of HID-Xenon lamps unless the lamps are turned off, the engine is turned off, the key is removed (if equipped), and you are wearing appropriate eye protection.

⚠ WARNING! Do not look directly into HID-Xenon lamps. Eye damage could occur.

Wear gloves and safety glasses when handling bulbs. Dangerous voltage sparks may occur and cause injury or damage to the connector. See manufacturer's warnings packaged with replacement bulbs.

Before working on the electrical system, either hit the main power disconnect switch, if equipped, or disconnect the battery cable(s).

- Remove the battery negative (-) cable(s) first.
- When reconnecting the battery, connect the battery negative (-) cable(s) last.

Battery Hazards

The liquid in batteries contains acid, which is a POISON and could cause SEVERE CHEMICAL BURNS.

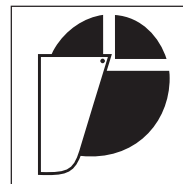

Wear face
protection

Avoid injury:

- Wear a face shield to prevent contact with your eyes.
- Wear chemical-resistant gloves and clothing to keep liquid off your skin and regular clothing.

⚠ WARNING! Liquids in batteries will damage eyes or skin on contact. **Always wear a face shield to avoid getting liquid in your eyes.**

If liquid from the battery contacts your eyes, flush immediately with clean water and get medical attention. **Wear chemical-resistant gloves and protective clothing to keep liquid off your skin.** If liquid contacts skin or clothing, wash off immediately with clean water. **If liquid is ingested,** drink large quantities of water or milk. DO NOT induce vomiting. Seek medical attention immediately.

Perform Maintenance Safely

Avoid Explosion

⚠ WARNING! Avoid serious injury from explosion. Lead-acid batteries produce extremely explosive gases especially when being charged. **Keep arcs, sparks, flames and lighted tobacco away.**

- Do not smoke near batteries.
- Keep them away from arcs, sparks and open flames.
- Provide adequate ventilation.

Never check the battery by placing a metal object across the battery posts. The resulting spark could cause an explosion.

⚠ WARNING! Avoid serious injury from battery explosion. **Do not charge a battery or jump-start the engine if the battery is frozen.**

Warm to 60°F (15.5°C) or the battery may explode and could cause serious injury.

Safety rules during battery jump-starting:

- Follow the instructions for proper battery jump-starting, as specified in the manufacturer's manual.
- Be sure the machines are not touching.
- Observe the polarity of the batteries and connections.

- Make the final cable connection to the engine or the furthest ground point away from the battery. Never make the final connection at the starter or dead battery. Sparks may ignite the explosive gases present at the battery.
- When disconnecting cables, remove the cables in reverse order of connection (e.g., final connection first).

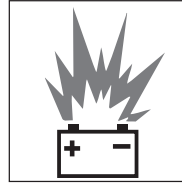

Avoid sparks and open flames near batteries

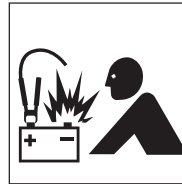

When jump-starting, observe polarity and make final connection at ground point

Toxic Chemical Disposal

For the safety of others and the environment, consult with your operator's manual or site supervisor for proper disposal of batteries and any chemicals or fluids.

39

Perform Maintenance Safely

Tire and Wheel Maintenance

Check your tires and wheels daily, if equipped, because the stability of the machine can be dramatically affected by tire pressure or damage to tires or wheels.

Check tires for:

- Correct pressure.
- Cuts and bulges.
- Nails or other punctures.
- Uneven or excessive wear.
- Condition of valve stems and caps.

Check wheels for:

- Damage to the rims.
- Missing or loose lug nuts or bolts.
- Misalignment.

All tire service should be performed by a qualified tire service center or by an authorized service person who has been properly trained in the procedures and use of safety equipment designed for tire servicing.

⚠ WARNING! The types of wheels and tires usually found on this equipment require special care when servicing to prevent death or serious injury. **Do not inflate the tires above the recommended pressure.**

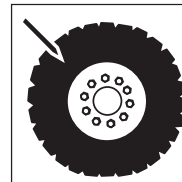

Check tires and wheels for damage



Maintain proper tire pressure

Perform Maintenance Safely

Keep wheel lug nuts tightened to manufacturer's recommendations.

An increase in tire pressure during operation is normal, and should NOT be reduced.

Never reinflate a tire that has been run flat or seriously under-inflated without removing the tire from the wheel. Have the tire and wheel closely inspected for damage before remounting.

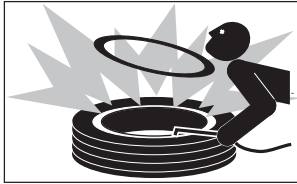

Avoid tire explosion

When adding air to a tire, do so from a distance. Always use a long hose with a self-attaching chuck; stand away from the tire sidewall and to one side as far as possible.

Do not inflate tires with flammable gases or from systems using an alcohol injector.

Never cut or weld on a wheel with an inflated tire mounted on it. This could cause explosive decompression.

Check that the tire size and wheel are correctly matched.

When replacing the tires, ensure the tires are of the appropriate rating specified by the manufacturer.

⚠ WARNING! Avoid death or serious injury. **Always use a safety cage or cable restraints when reinflating a repaired tire.**

Tires should not be operated at speeds higher than their rated speed.

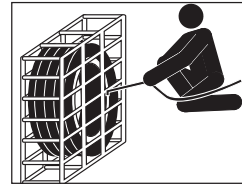

Use safety devices when reinflating tires

41

Perform Maintenance Safely

Roll-Over Protective Structure (ROPS) and Falling Object Protective Structure (FOPS) Safety Precautions

Do not remove the ROPS/FOPS except for service. Reinstall them correctly before allowing the machine back into service.

Do not modify ROPS/FOPS in any manner.

Unauthorized modifications such as welding, drilling, cutting or adding attachments could weaken the structure and reduce your protection. Replace ROPS/FOPS if subjected to rollover or damage. Do NOT attempt to repair them. See the manufacturer's manual(s) for complete instructions and inspection requirements.

If your machine is equipped with a foldable ROPS, make sure it is upright whenever the machine is in use.

Complete Service and Repairs Before Machine is Released

Tighten all bolts, fittings, and connections to torques specified by the manufacturer.

Are there any missing cotter pins, washers, locknuts, etc.? Are there any parts left over?

Start the engine and check for leaks. (See page 36, **Hydraulic System Hazards**.) Operate all controls to make sure the machine is functioning properly. Test the machine if necessary. After testing, shut down and check the work you performed.

Recheck all fluid levels before releasing the equipment for operation.

All parts should be inspected during repair and replaced if worn, cracked or damaged. Excessively worn or damaged parts could fail and cause injury or death.

Install all guards, covers, and shields after servicing. Refill and recharge pressure systems only with manufacturer-approved or recommended fluids.



Verify service work when completed

Final Word to the User

You have just finished reading the AEM Roller Compactor Safety Manual. It is impossible for this manual to cover every safety situation that you may encounter on a daily basis. Your knowledge of these safety precautions and your application to the basic rules of safety will help to build good judgment in all situations. Our objective is to help you develop, establish and maintain good safety habits to make operating a roller compactor easier and safer for you.

Many pictorials in this safety manual can be downloaded at <http://pictorials.aem.org>.

For additional publications, visit our website at www.safetymaterials.org.

43



ASSOCIATION OF
EQUIPMENT MANUFACTURERS



e-mail safetymaterials@aem.org
www.aem.org

This manual is one in a series on the safe operation of machinery, published by AEM.



To order AEM safety materials
visit www.safetymaterials.org.



14 Schematics

Notes

14.1 Electrical Schematic—Complete—Kohler

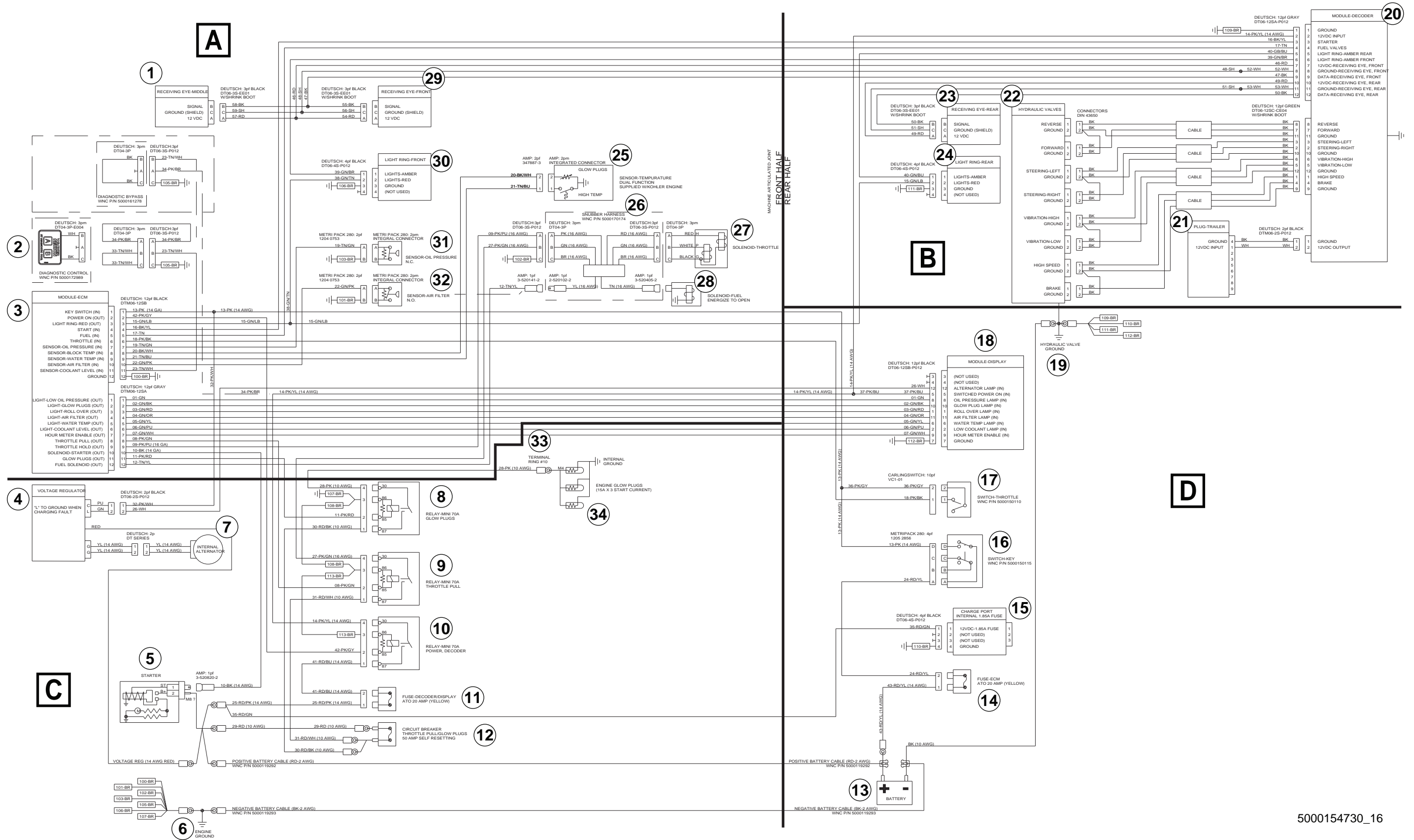

5000154730_16

14.2 Electrical Schematic Components—Kohler

Ref.	Description
1	Receiving eye—middle
2	Diagnostic tool
3	Module—engine control module (ECM)
4	Voltage regulator
5	Starter
6	Engine ground
7	Internal alternator
8	Relay—glow plugs
9	Relay—throttle pull
10	Relay—Power decoder
11	Fuse—decoder/display
12	Circuit breaker
13	Battery
14	Fuse—engine control module (ECM)
15	Charge port
16	Key switch
17	Throttle switch
18	Module—display
19	Hydraulic valve ground
20	Module—decoder
21	Plug—trailer
22	Hydraulic valves
23	Receiving eye—rear
24	Light ring—rear
25	Sensor—temperature
26	Snubber harness
27	Solenoid—throttle
28	Solenoid—fuel energize to open
29	Receiving eye—front
30	Light ring—front
31	Sensor—oil pressure

Ref.	Description
32	Sensor—air filter
33	Terminal ring
34	Engine glow plugs

Wire Colors							
BK	Black	RD	Red	YL	Yellow	OR	Orange
GN	Green	TN	Tan	BR	Brown	PU	Purple
BU	Blue	VIO	Violet	CL	Clear	SH	Shield
PK	Pink	WH	White	GY	Gray	LB	Lt. blue

14.3 Electrical Schematic Section A—Kohler

A

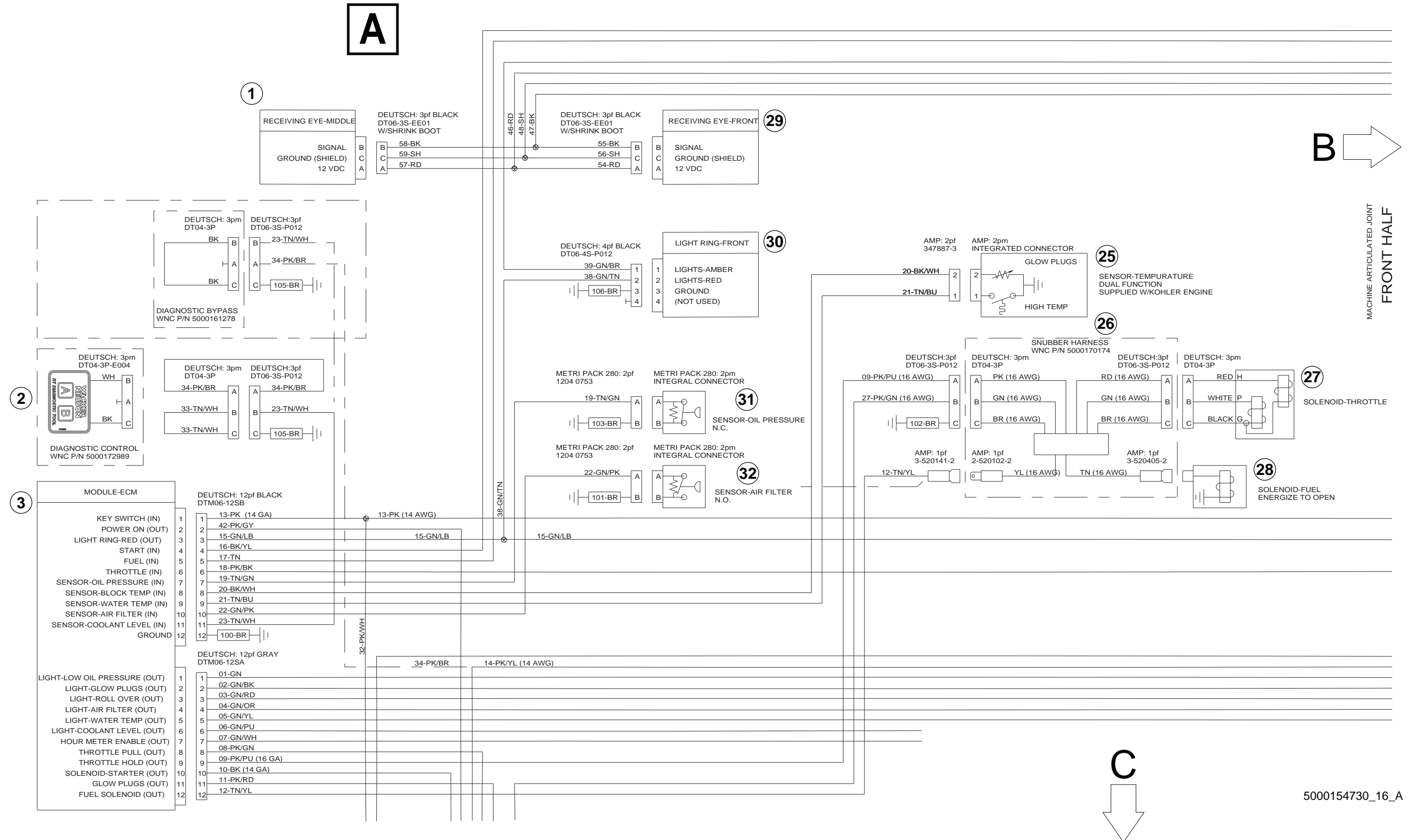

B →

MACHINE ARTICULATED JOINT
FRONT HALF

C ↓

5000154730_16_A

14.4 Electrical Schematic Components—Kohler

Ref.	Description
1	Receiving eye—middle
	Signal
	Ground (shield)
	12 VDC
2	Diagnostic tool
3	Module—engine control module (ECM)
	Key switch (in)
	Power on (out)
	Light ring-red (out)
	Start (in)
	Fuel (in)
	Throttle (in)
	Sensor—oil pressure (in)
	Sensor—block temperature (in)
	Sensor—water temperature (in)
	Sensor—air filter (in)
	Sensor—coolant level (in)
	Ground
	Light—low oil pressure (out)
	Light—glow plugs (out)
	Light—roll over (out)
	Light—air filter (out)
	Light—water temperature (out)
	Light—coolant level (out)
	Hour meter enable (out)
	Throttle pull (out)
	Throttle hold (out)
	Solenoid—starter (out)
	Glow plugs (out)
	Fuel solenoid (out)
25	Sensor—temperature

Ref.	Description
	Glow plugs
	High temperature
26	Snubber harness
27	Solenoid—throttle
28	Solenoid—fuel energize to open
29	Receiving eye—front
	Signal
	Ground (shield)
	12 VDC
30	Light ring—front
	Lights—amber
	Light—red
	Ground
	(Not used)
31	Sensor—oil pressure
32	Sensor—air filter

Wire Colors							
BK	Black	RD	Red	YL	Yellow	OR	Orange
GN	Green	TN	Tan	BR	Brown	PU	Purple
BU	Blue	VIO	Violet	CL	Clear	SH	Shield
PK	Pink	WH	White	GY	Gray	LB	Lt. blue

14.5 Electrical Schematic Section B—Kohler

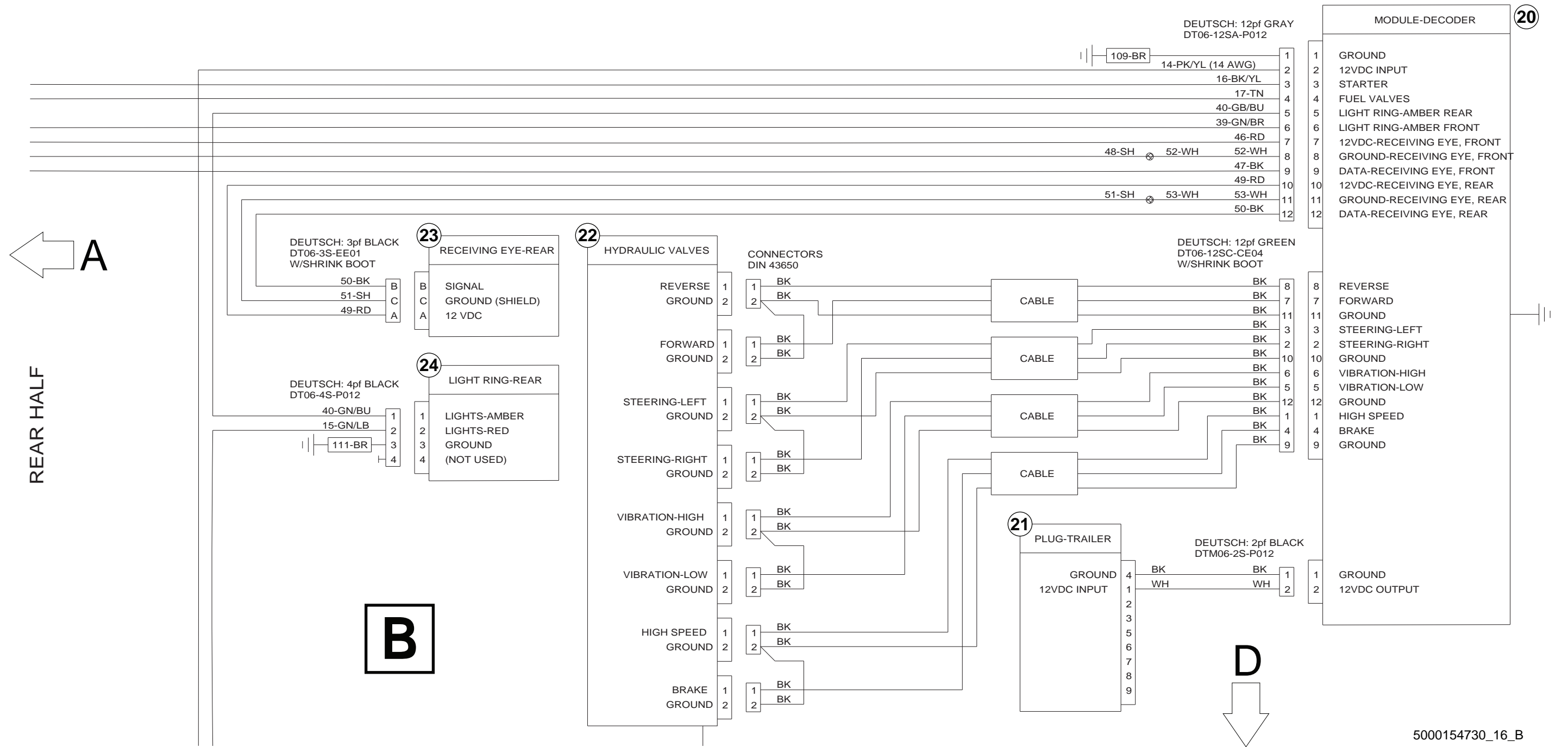

5000154730_16_B

14.6 Electrical Schematic Components—Kohler

Ref.	Description
20	Module—decoder
	Ground
	12 VDC input
	Starter
	Fuel valves
	Light ring—amber rear
	Light ring—amber front
	12 VDC—receiving eye, front
	Ground—receiving eye, front
	Data—receiving eye, front
	12 VDC—receiving eye, rear
	Ground—receiving eye, rear
	Data—receiving eye, rear
	Reverse
	Forward
	Ground
	Steering—left
	Steering—right
	Ground
	Vibration—high
	Vibration—low
	Ground
	High speed
	Brake
	Ground
	Ground
	12 VDC output
21	Plug—trailer
	Ground
	12 VDC input
22	Hydraulic valves

Ref.	Description
	Reverse
	Ground
	Forward
	Ground
	Steering—left
	Ground
	Steering—right
	Ground
	Vibration—high
	Ground
	Vibration—low
	Ground
	High speed
	Ground
	Brake
	Ground
23	Receiving eye—rear
	Signal
	Ground (shield)
	12 VDC
24	Light ring—rear
	Light—amber
	Lights—red
	Ground
	(Not used)

14.7 Electrical Schematic Section C—Kohler

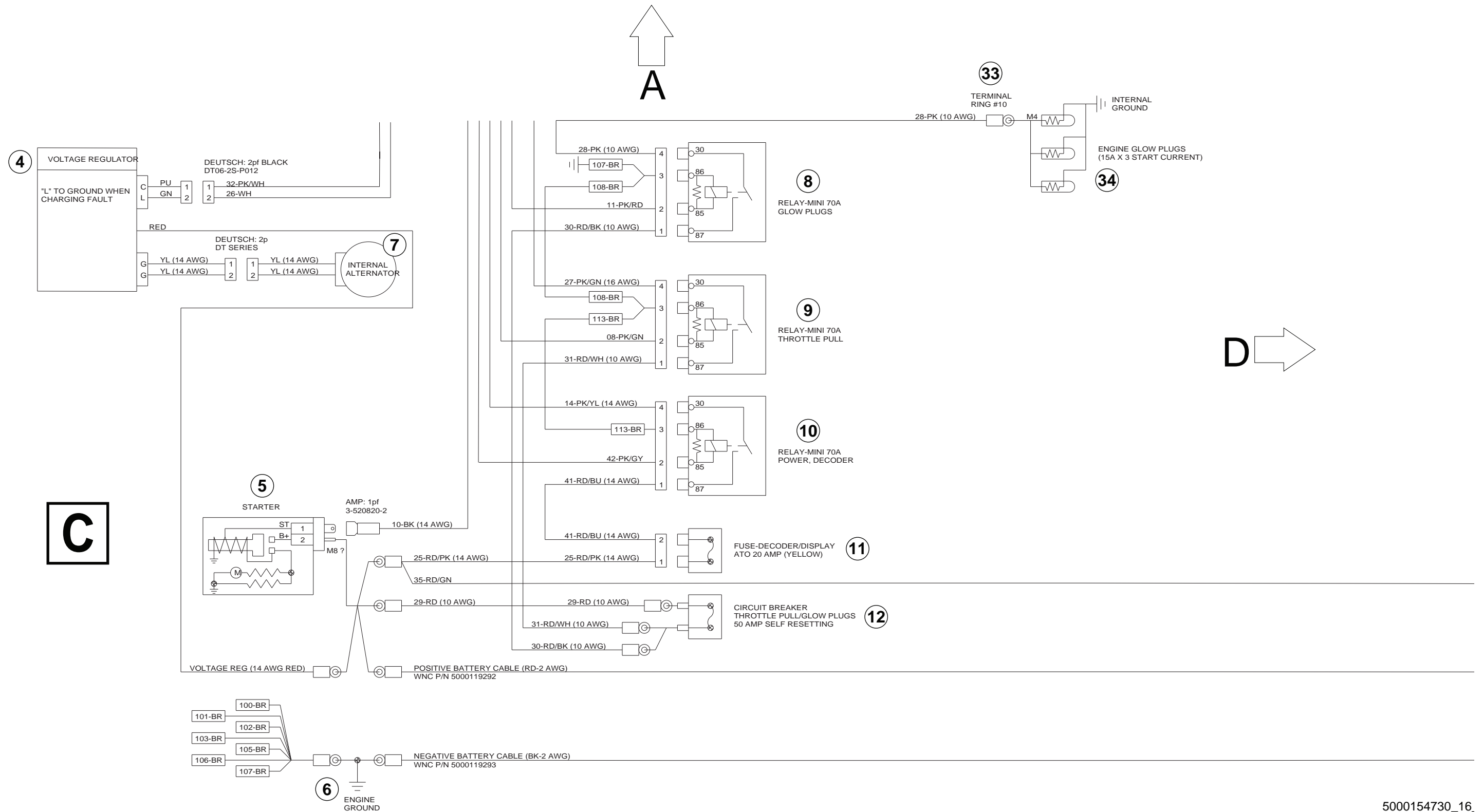

5000154730_16

14.8 Electrical Schematic Components—Kohler

Ref.	Description
4	Voltage regulator
	L to ground when charging fault
5	Starter
6	Engine ground
7	Internal alternator
8	Relay—glow plugs
9	Relay—throttle pull
10	Relay—Power decoder
11	Fuse—decoder/display
12	Circuit breaker
33	Terminal ring
34	Engine glow plugs

Wire Colors							
BK	Black	RD	Red	YL	Yellow	OR	Orange
GN	Green	TN	Tan	BR	Brown	PU	Purple
BU	Blue	VIO	Violet	CL	Clear	SH	Shield
PK	Pink	WH	White	GY	Gray	LB	Lt. blue

14.9 Electrical Schematic Section D—Kohler

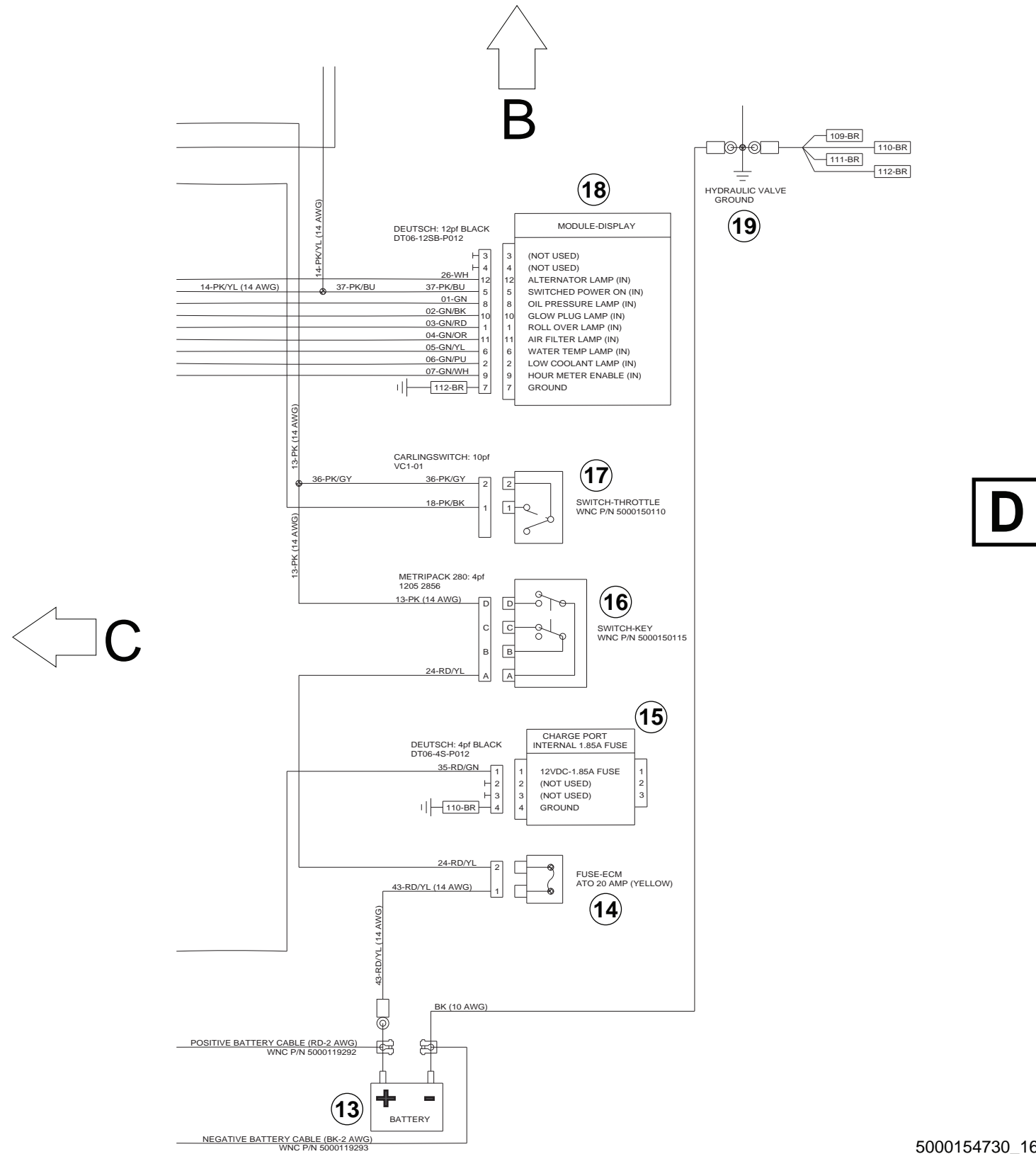

5000154730_16_D

14.10 Electrical Schematic Components—Kohler

Ref.	Description
13	Battery
14	Fuse—engine control module (ECM)
15	Charge port
	12 VDC—1.85A fuse
	(Not used)
	(Not used)
	Ground
16	Key switch
17	Throttle switch
18	Module—display
	(Not used)
	(Not used)
	Alternator lamp (in)
	Switched power on (in)
	Oil pressure lamp (in)
	Glow plug lamp (in)
	Roll over lamp (in)
	Air filter lamp (in)
	Water temperature lamp (in)
	Low coolant lamp (in)
	Hour meter enable (in)
	Ground
19	Hydraulic valve ground

Wire Colors							
BK	Black	RD	Red	YL	Yellow	OR	Orange
GN	Green	TN	Tan	BR	Brown	PU	Purple
BU	Blue	VIO	Violet	CL	Clear	SH	Shield
PK	Pink	WH	White	GY	Gray	LB	Lt. blue

14.11 Electrical Schematic—Complete—Kubota

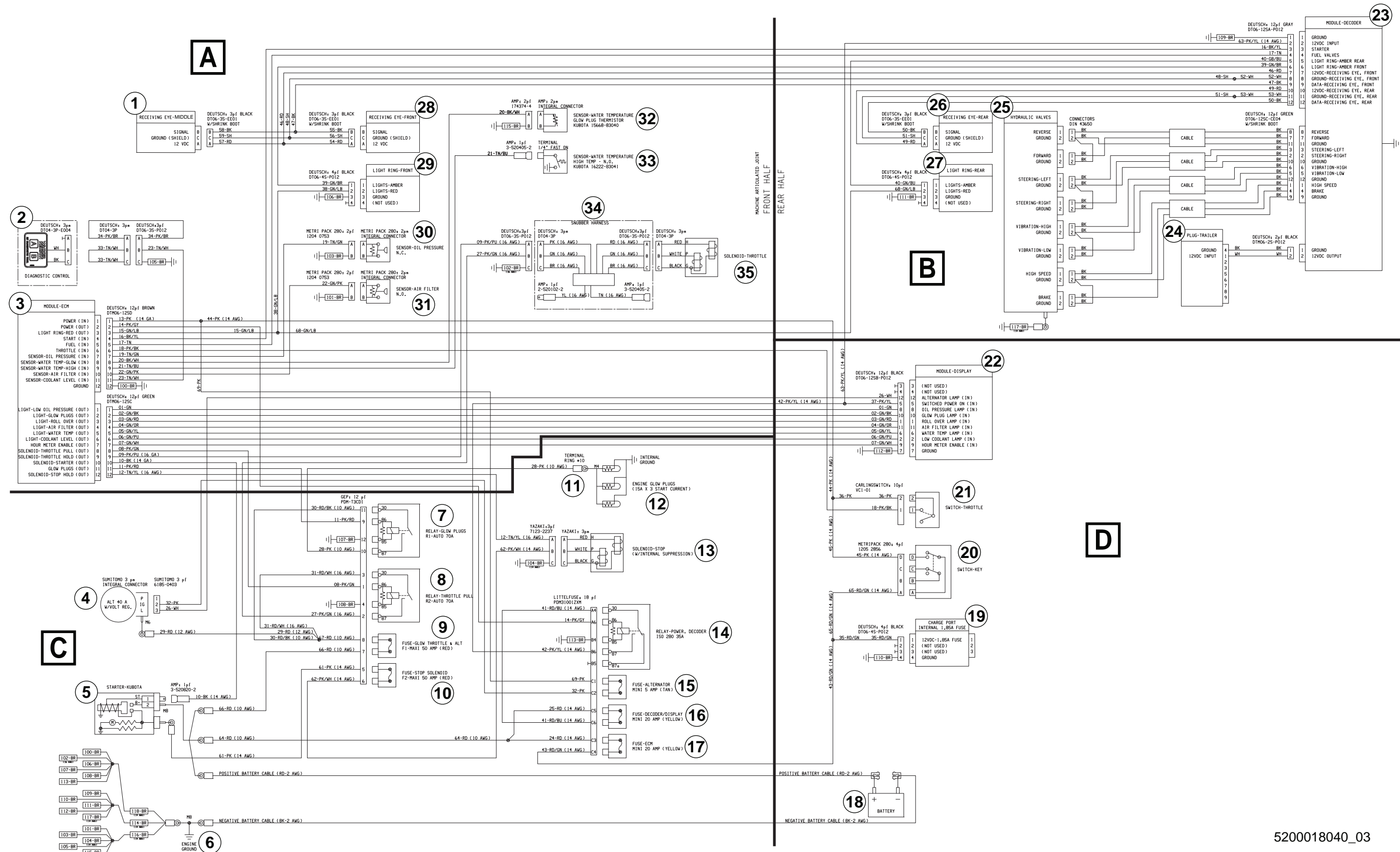

5200018040_03

14.12 Electrical Schematic Components—Kubota

Ref.	Description
1	Receiving eye—middle
2	Diagnostic tool
3	Module—engine control module (ECM)
4	Alternator with voltage regulator
5	Starter
6	Engine ground
7	Relay—glow plugs
8	Relay—throttle pull
9	50A fuse—glow plugs, throttle, and alternator
10	50A fuse—stop solenoid
11	Terminal ring
12	Engine glow plugs
13	Stop solenoid
14	Relay—power decoder
15	5A fuse—alternator
16	20A fuse—decoder/display
17	20A fuse—engine control module (ECM)
18	Battery
19	Charge port
20	Key switch
21	Throttle switch
22	Module—display
23	Module—decoder
24	Plug—trailer
25	Hydraulic valves
26	Receiving eye—rear
27	Light ring—rear
28	Receiving eye—front
29	Light ring—front
30	Sensor—oil pressure
31	Sensor—air filter

Ref.	Description
32	Sensor—water temperature (glow plug thermistor)
33	Sensor—water temperature (high water temperature)
34	Snubber harness
35	Solenoid—throttle

Wire Colors							
BK	Black	RD	Red	YL	Yellow	OR	Orange
GN	Green	TN	Tan	BR	Brown	PU	Purple
BU	Blue	VIO	Violet	CL	Clear	SH	Shield
PK	Pink	WH	White	GY	Gray	LB	Lt. blue

14.13 Electrical Schematic Section A—Kubota

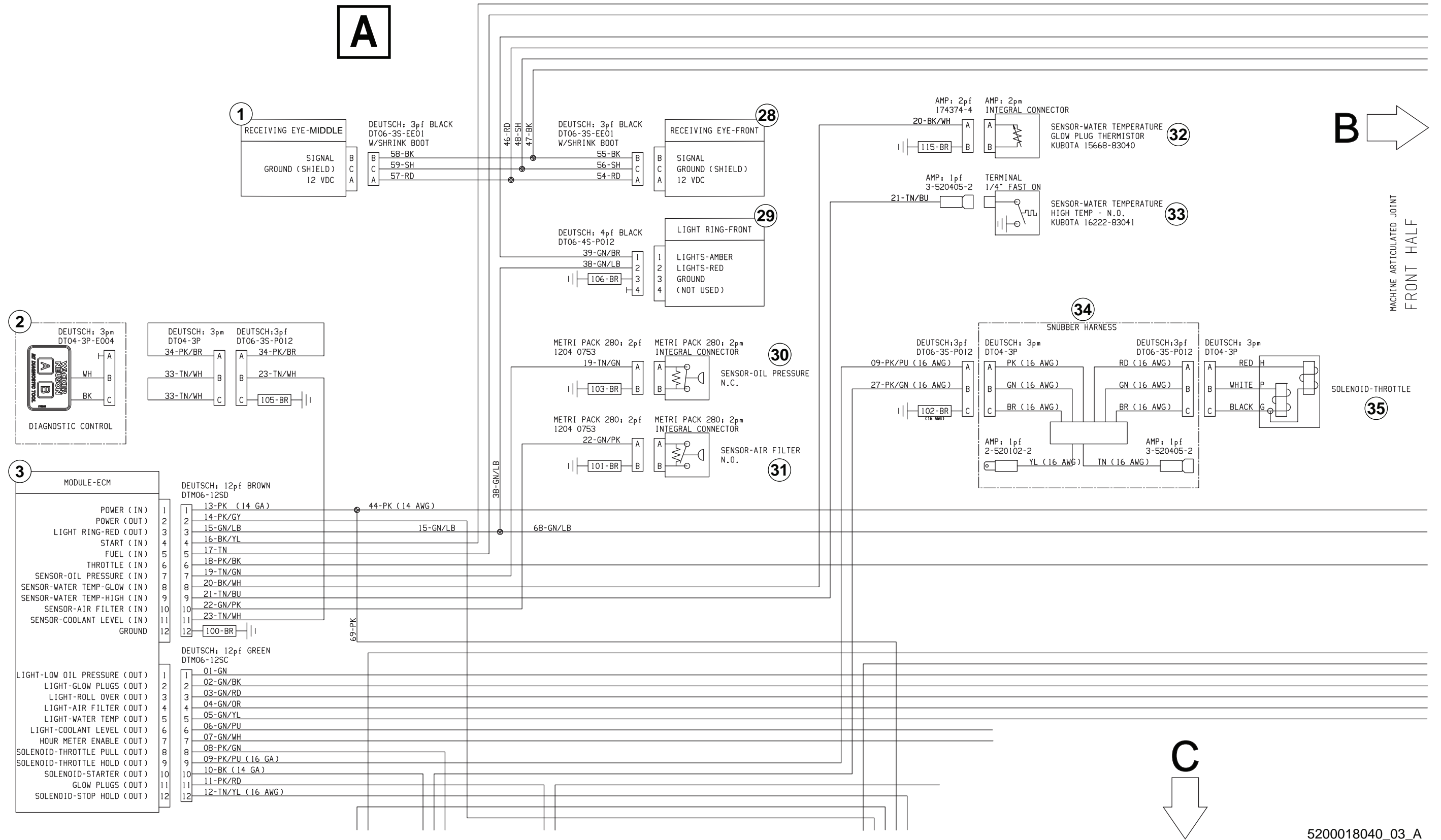

5200018040_03_A

14.14 Electrical Schematic Components—Kubota

Ref.	Description
1	Receiving eye—middle
	Signal
	Ground (shield)
	12 VDC
2	Diagnostic tool
3	Module—engine control module (ECM)
	Power (in)
	Power (out)
	Light ring-red (out)
	Start (in)
	Fuel (in)
	Throttle (in)
	Sensor—oil pressure (in)
	Sensor—water temperature-glow plugs (in)
	Sensor—water temperature high (in)
	Sensor—air filter (in)
	Sensor—coolant level (in)
	Ground
	Light—low oil pressure (out)
	Light—glow plugs (out)
	Light—roll over (out)
	Light—air filter (out)
	Light—water temperature (out)
	Light—coolant level (out)
	Hour meter enable (out)
	Solenoid—throttle pull (out)
	Solenoid—throttle hold (out)
	Solenoid—starter (out)
	Glow plugs (out)
	Solenoid—stop hold (out)

Ref.	Description
28	Receiving eye—front
	Signal
	Ground (shield)
	12 VDC
29	Light ring—front
	Lights—amber
	Lights—red
	Ground
	(Not used)
30	Sensor—oil pressure
31	Sensor—air filter
32	Sensor—water temperature (glow plug thermistor)
33	Sensor—water temperature (high water temperature)
34	Snubber harness
35	Solenoid—throttle

Wire Colors							
BK	Black	RD	Red	YL	Yellow	OR	Orange
GN	Green	TN	Tan	BR	Brown	PU	Purple
BU	Blue	VIO	Violet	CL	Clear	SH	Shield
PK	Pink	WH	White	GY	Gray	LB	Lt. blue

14.15 Electrical Schematic Section B—Kubota

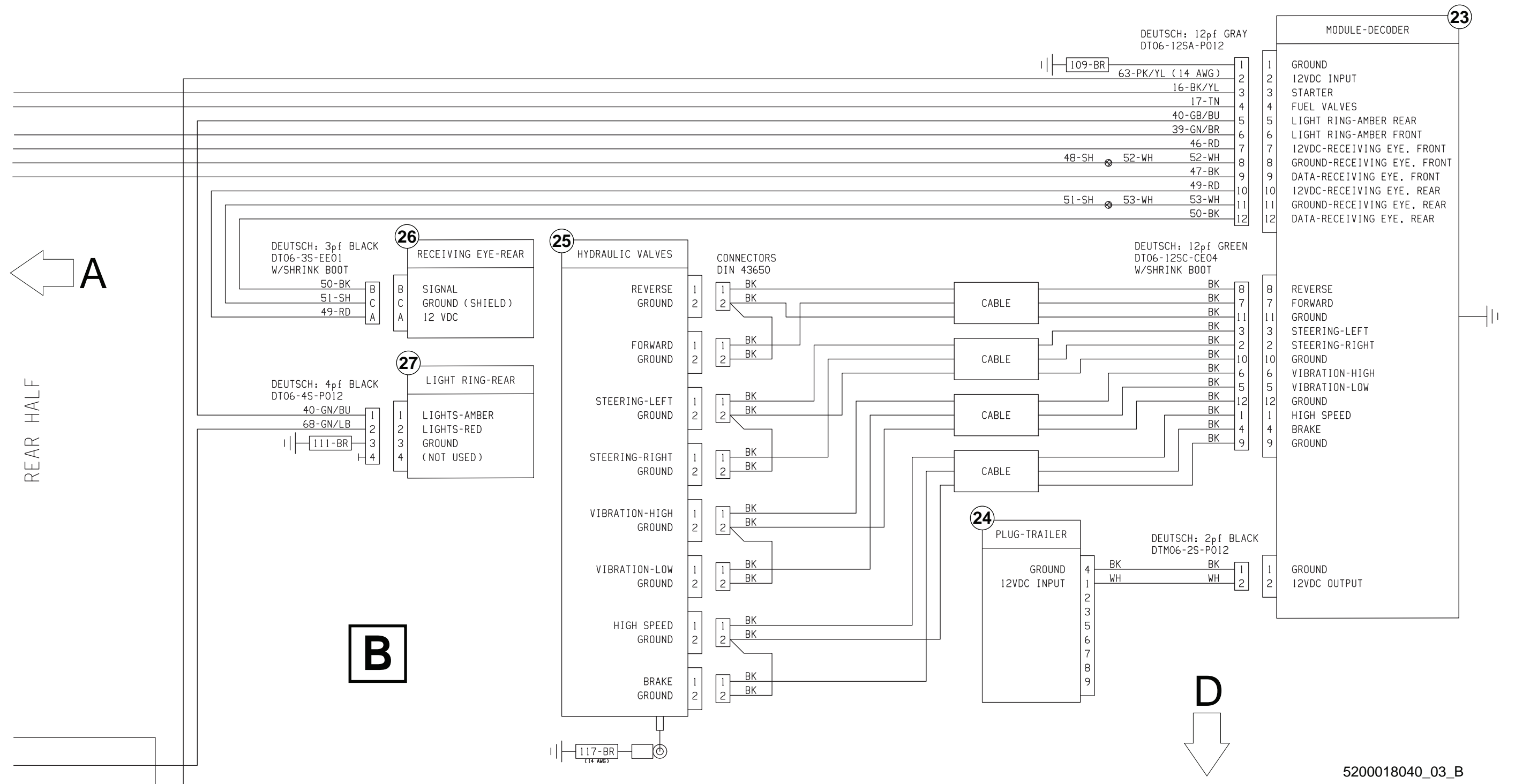

5200018040_03_B

14.16 Electrical Schematic Components—Kubota

Ref.	Description
23	Module—decoder
	Ground
	12 VDC Input
	Starter
	Fuel valves
	Light ring—amber rear
	Light ring—amber front
	12 VDC—receiving eye, front
	Ground—receiving eye, front
	Data—receiving eye, rear
	12 VDC—receiving eye, rear
	Ground—receiving eye, rear
	Data—receiving eye, rear
	Reverse
	Forward
	Ground
	Steering—left
	Steering—right
	Ground
	Vibration—high
	Vibration—low
	Ground
	High speed
	Brake
	Ground
24	Plug—trailer
	Ground
	12 VDC input
25	Hydraulic valves

Ref.	Description
	Reverse
	Ground
	Forward
	Ground
	Steering—right
	Ground
	Steering—left
	Ground
	Vibration—high
	Ground
	Vibration—low
	Ground
	High speed
	Ground
	Brake
	Ground
26	Receiving eye—rear
	Signal
	Ground (shield)
	12 VDC
27	Light ring—rear
	Lights—amber
	Lights—red
	Ground
	(Not used)
28	Receiving eye—front

14.17 Electrical Schematic Section C—Kubota

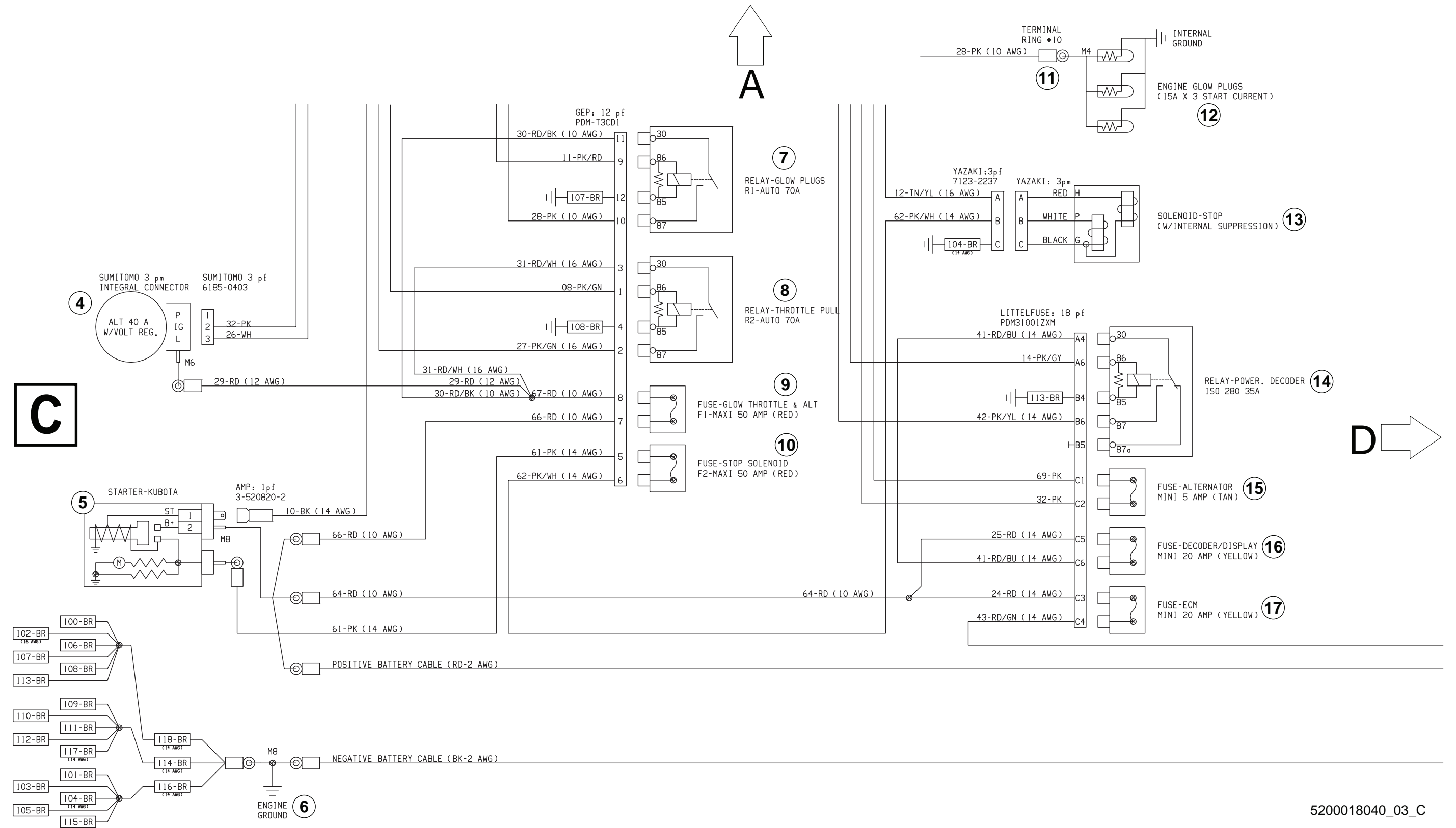

5200018040_03_C

14.18 Electrical Schematic Components—Kubota

Ref.	Description
4	Alternator with voltage regulator
5	Starter
6	Engine ground
7	Relay—glow plugs
8	Relay—throttle pull
9	50A fuse—glow plugs, throttle, and alternator
10	50A fuse—stop solenoid
11	Terminal ring
12	Engine glow plugs
13	Stop solenoid
14	Relay—power decoder
15	5A fuse—alternator
16	20A fuse—decoder/display
17	20A fuse—engine control module (ECM)

Wire Colors							
BK	Black	RD	Red	YL	Yellow	OR	Orange
GN	Green	TN	Tan	BR	Brown	PU	Purple
BU	Blue	VIO	Violet	CL	Clear	SH	Shield
PK	Pink	WH	White	GY	Gray	LB	Lt. blue

14.19 Electrical Schematic Section D—Kubota

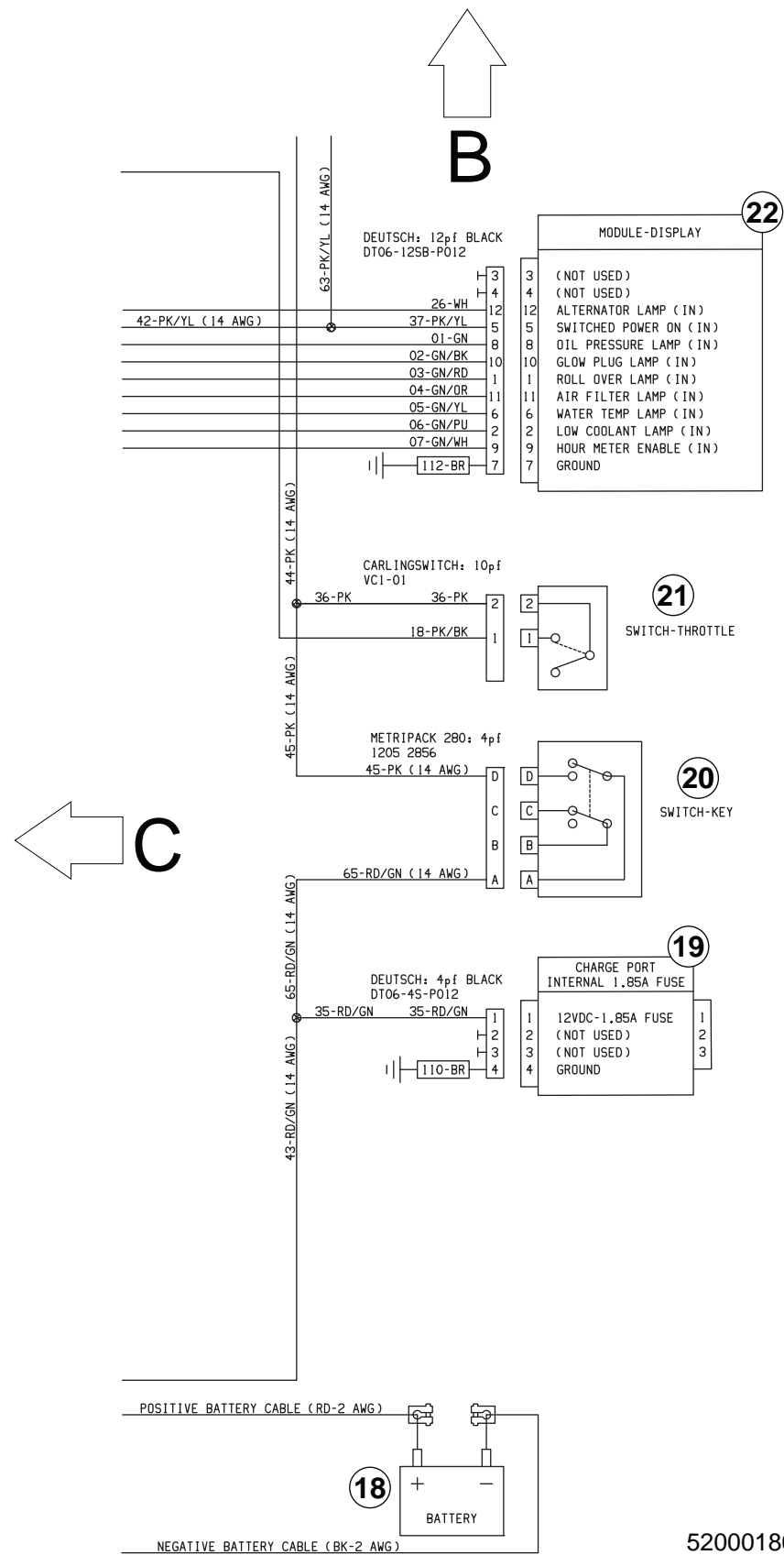

5200018040_03_D

14.20 Electrical Schematic Components—Kubota

Ref.	Description
18	Battery
19	Charge port
	12 VDC—1.85A fuse
	(Not used)
	(Not used)
	Ground
20	Key switch
21	Throttle switch
22	Module—display
	(Not used)
	(Not used)
	Alternator lamp (in)
	Switched power on (in)
	Oil pressure lamp (in)
	Glow plug lamp (in)
	Roll over lamp (in)
	Air filter lamp (in)
	Water temperature lamp (in)
	Low coolant lamp (in)
	Hour meter enable (in)
	Ground

Wire Colors							
BK	Black	RD	Red	YL	Yellow	OR	Orange
GN	Green	TN	Tan	BR	Brown	PU	Purple
BU	Blue	VIO	Violet	CL	Clear	SH	Shield
PK	Pink	WH	White	GY	Gray	LB	Lt. blue

14.21 Hydraulic Schematic

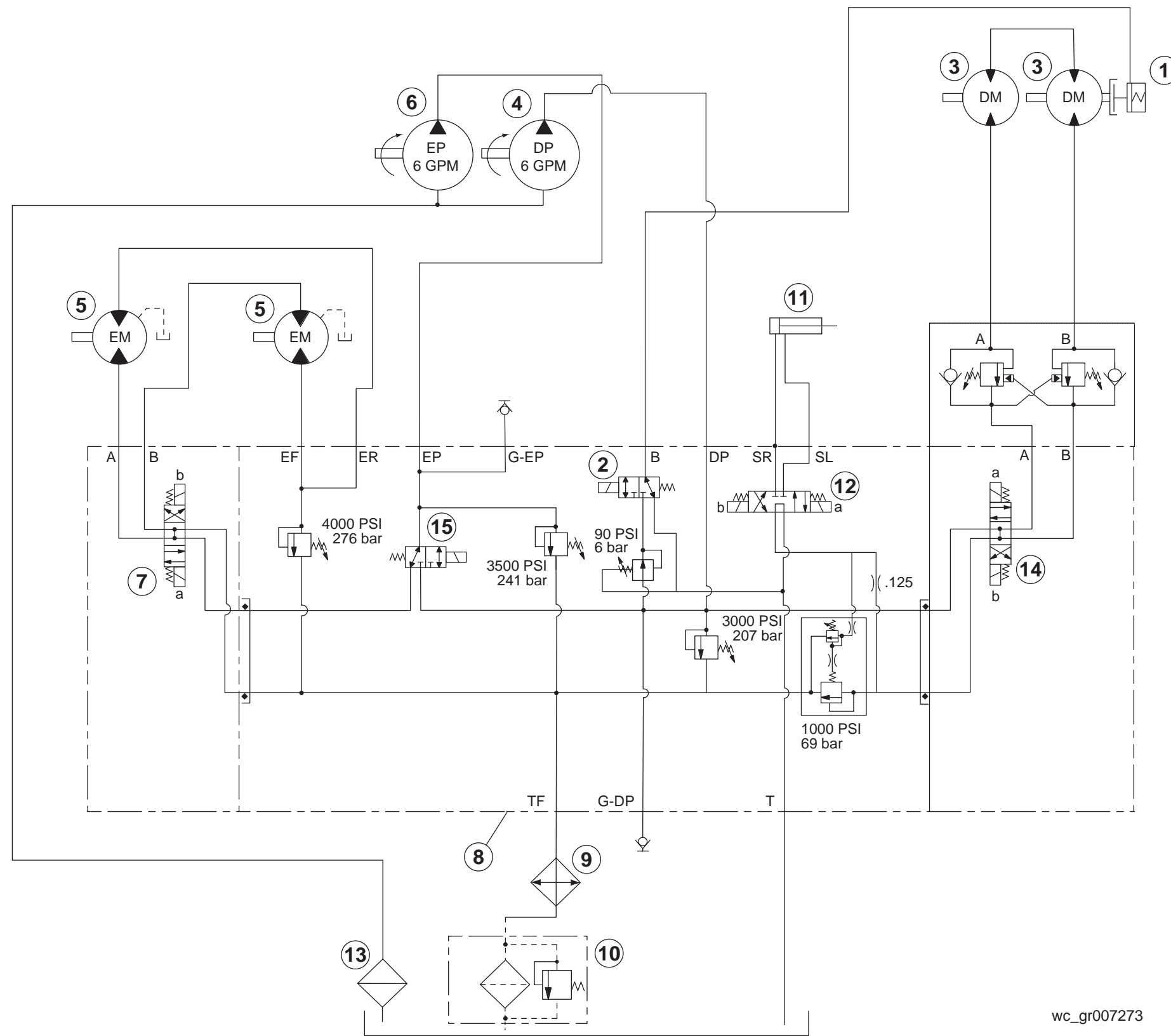

wc_gr007273

14.22 Hydraulic Schematic Components

Ref.	Description	Ref.	Description
1	Parking brake	9	Oil cooler
2	Brake valve	10	Return line filter
3	Drive motor	11	Steering cylinder
4	Drive pump	12	Steering valve
5	Exciter motor	13	Suction strainer
6	Exciter pump	14	Travel valve
7	Exciter (vibration) valve	15	High-speed travel valve
8	Control manifold	—	—

